

UK P&I CLUB 

RISK FOCUS: CONSOLIDATED 2017

Identifying major areas of risk



UK P&I CLUB
IS MANAGED
BY **THOMAS
MILLER**

CONTENTS

Kidnap and Ransom	3-18
Paint	19-32
Engine Room Fires	33-50
Hatch Covers	51-72
Fishing Vessels	73-94

UK P&I CLUB 

UK WAR RISKS 

HELLENIC
WAR RISKS 

Terra Firma
Risk Management

RISK FOCUS: KIDNAP AND RANSOM

Anatomy of West African maritime kidnappings – A guide for seafarers

Cover: Arrested pirates that hijacked the Panama-flagged Maximus vessel in 2016 are handcuffed and shown to the media in Lagos. Nigerian sailors rescued a hijacked oil tanker in a dramatic night-time rescue in which one of the pirates was killed. (Credit: AP Photo/Sunday Alamba)

Anatomy of West African maritime kidnap – A seafarers' guide

The Gulf of Guinea is currently thought to be the most dangerous region for seafarers. According to a recent report by Oceans Beyond Piracy¹, the total number of kidnaps for ransom during 2016 in the Gulf of Guinea has already surpassed the total number of incidents recorded by the International Maritime Bureau (IMB) for 2015.

The IMB itself has recorded 10 incidents in the Gulf of Guinea in the first quarter of 2016, and the kidnap of 16 seafarers². Since April 2015, the Merchant Trade Information Sharing Centre for the Gulf of Guinea (MTISC-GoG) recorded 56 incidents in the area and the kidnap of 35 seafarers³. The increase in kidnapping for ransom has not occurred out of the blue: in 2014, 16% of attacks in the area involved kidnap for ransom; in 2015 it was 28% of attacks.

The costs of protecting vessels in the region are well known. The attacks on vessels and the kidnapping of seafarers in this region, however, have a further impact on business. Owners and crewing agencies may find it increasingly hard to crew ships in these waters, especially with nationalities that have the appropriate experience, languages and skills set.

This report explains why kidnapping for ransom has increased recently in the Gulf of Guinea, and assesses whether this increase will continue. It describes what



happens during a kidnap, and provides some insight into the training available for shipping companies and crews.

Observations from Richard Neylon and Mike Ritter of Holman Fenwick Willan (HFW)

HFW's lawyers provide a comprehensive service to the global maritime business community, with over 400 lawyers and 18 Master Mariners worldwide specialising in maritime law.

Q. What is the impact of West African piracy on business, operations and finances of a shipowner?

A. The majority of cases this year have lasted around 21-28 days and have involved a payment of a ransom to secure the release of the crew members, although recent cases have taken longer and involved higher payments. In addition to this direct cost, there are the costs of professional consultants, local logistics companies, lawyers, security, medical, repatriation and other ancillary expenses. This can considerably affect the cash flow for a shipowner.

In addition to this, the remaining crew need to be cared for and the shipowner might face delays and expenses whilst the vessel calls into a port of refuge or is subject to an authority investigation, typically resulting in loss of hire. There might also be physical damage to the vessel and her equipment. Handling a kidnap also requires a large investment of time by the shipowners' operations team and management alongside their day-to-day tasks.

More generally, all shipowners face costs arising from the deployment of anti-piracy measures and/or armed guards to combat the problem. N.B. The legality of the use of armed guards in Nigeria is a tricky area on which specific advice should be sought.

richard.neylon@hfw.com / michael.ritter@hfw.com

¹ <http://oceansbeyondpiracy.org/publications/gulf-guinea-2016-trends> ² ICC – IMB Piracy and Armed Robbery Against Ships Report – First Quarter 2016
³ As of June 2016 there are significant changes to the reporting mechanism for vessels operating in the Gulf of Guinea area, with the closure of the MTISC-GoG and the opening of the Marine Domain Awareness for Trade – Gulf of Guinea service (MDAT-GoG).



The political background ashore

Piracy and kidnapping do not happen in a vacuum – there are reasons why so many cases of kidnapping occur in the Gulf of Guinea at the moment.

In terms of maritime kidnap, Nigeria is without doubt the key. Maritime kidnaps sometimes occur outside Nigerian waters, and occasionally abducted seafarers are held outside, or on the margins of, Nigerian territory but there is almost always a significant Nigerian connection. Awareness of the the Nigerian political situation is vital to understanding the kidnap threat in the Gulf of Guinea.

Nigeria currently faces a number of serious threats. Boko Haram is one, mainly in the North and East of the country. The Nigerian armed forces have made heavy weather of tackling Boko Haram, and are still heavily committed. Although the situation has improved militarily in 2015 and so far in 2016, a sustainable political solution is still far off.

In the South, the situation is very different but also far from stable. Until 2009, an insurgency in the Niger Delta was fought against the government, with an organisation called MEND (the Movement for the Emancipation of the Niger Delta) in the forefront. An amnesty was declared by a previous president in 2009. Many weapons were handed in to the authorities but the insurgent groups were never disbanded – indeed, they were given good reason to stay together because the government paid both them and their leaders in return for refraining from violence. The current president, Muhammadu Buhari, wants to break up these groups and he has cut back on some of the lucrative government contracts enjoyed by these gangs and their leaders. The president has also threatened to arrest a leading militant, known as 'Tompson'. The insurgent groups have responded to this threat from the government with an increase in attacks on oil pipelines (with consequent environmental pollution).

In 2016, however, the situation has become even more complicated. Newly formed insurgent groups, such as the Niger Delta Avengers, have attacked groups of police and soldiers in a direct challenge to the state and have warned some foreign oil companies to leave the area. Some analysts believe that the Niger Delta Avengers are challenging not only the government, but also the established insurgent groups such as Tompolo's, who they believe have reached unpublicised agreements with the government. There is clearly money and training behind the Niger Delta Avengers but it is not yet clear who, if anyone, is supporting and sponsoring them. The advent this month of even newer groups such as the Asawana Deadly Force of the Niger Delta underlies the scale of the challenge facing the government. It is thought that northern politicians

exploited the Boko Haram movement to destabilise the previous Nigerian president, and it is likely that some southern politicians are similarly exploiting this situation for their own political ends.

Some separatist groups exist in southern Nigeria, and there is frequent talk of a renewal of Biafran activism⁴. There may be a nascent link between some Niger Delta insurgents and Biafran activists, but there is no known link between the kidnaps of seafarers in the Gulf of Guinea and Biafran political activists. So far, all kidnaps have been undertaken exclusively for financial gain, and there have been no political demands made for the return of kidnapped seafarers in this area.

So far, all kidnaps have been undertaken exclusively for financial gain, and there have been no political demands made for the return of kidnapped seafarers in this area.

There may be two other reasons why kidnapping has increased in late 2015 and 2016. Improved naval patrolling (by the Nigerian and other littoral navies) may have made cargo theft more difficult and dangerous. Cargo theft, particularly of large amounts of refined oil products, takes time and so criminals have moved to a crime which takes less time on vessels and leaves them less exposed to naval patrols, i.e., the kidnap for ransom of ships' crews. In addition, it may be that for the time being, the drop in oil prices has made oil theft a less lucrative proposition than kidnap for ransom.

Looking to the future, a rapprochement between the federal government and the insurgent group leaders appears unlikely, particularly given that the current state of lawlessness suits the agenda of a number of political leaders. It is possible that the Niger Delta insurgency may resume in earnest, and the criminal kidnap gangs may be joined, and possibly co-opted, by kidnap gangs run by the insurgents, as was often the case before 2009.

⁴ The Biafran war took place from 1967-1970, when the Nigerian state countered Igbo tribal separatist demands. Widespread famine was one of the consequences.



Arrested pirates that hijacked the Panama-flagged Maximus vessel in 2016 are handcuffed and shown to the media in Lagos. Nigerian sailors rescued a hijacked oil tanker in a dramatic night-time rescue in which one of the pirates was killed. (Credit: AP Photo/Sunday Alamba)

Who are the kidnappers?

Kidnap gangs do not appear to be linked to the Delta's insurgent groups, although they thrive in an environment where law and order is all but absent, and are motivated by money rather than politics.

The organisation of Delta kidnap gangs varies enormously. Sometimes the leader is involved in the abduction and is very much present during captivity and negotiation – some kidnapper negotiators, for instance, appear also to be the leader of the group and do not refer to a senior person for important decisions. Other negotiators, however, have to wait for important decisions from shadowy figures, who rarely, if ever, appear.

Some of the gangs have at least 60 members, with some of the guards coming from as far away as Lagos. Most guards speak some English, even if it can be very difficult to understand. The discipline of gangs varies: guards often have access to both alcohol and drugs with predictable consequences. On the other hand, some ex-hostages have told of severe beatings meted out to guards caught, for instance, asleep at their sentry post.

Nigerian maritime kidnap gangs are thought to hold their hostages in all the Delta states, from Delta to Cross River and, on occasions, into the Cameroonian zone of Bakassi to the east of Cross River state.



What happens during a kidnap?

Kidnap abductions are always dangerous, and those in the Gulf of Guinea are no exception. The kidnapers often fire their weapons at and around the bridge in order to intimidate the crew, and a number of crew members have been killed or badly injured during such abductions.

There are signs that some Niger Delta gangs may be increasingly well drilled and organised. After a recent abduction, crew noted that the attackers were so well drilled that their leaders did not have to shout orders. The kidnapers use very fast speedboats (on a recent case, with two 200 horsepower engines) and board the vessel before the crew has time to react. In a number of recent cases, kidnapers have selected hostages from among the crew, preferring non-African to African hostages. Kidnapers appear to believe that the whiter the skin, the higher the ransom they will gain, so they will generally take the lightest-skinned hostages available. Nigerian and other African seafarers are often kidnapped, for instance off the many oil supply services vessels in the area, but the ransoms paid for them are generally much lower. Kidnapers will take quite large numbers of hostages, with six Turkish seafarers recently taken in one event. In another recent incident, four hostages were forced off their vessel into the kidnapers' speedboat, only to find that there were four hostages from two other vessels were already on board. The kidnapers will also take the opportunity to steal cash, mobiles, satellite phones and computers from the vessel, but most abductions now take no more than 20-30 minutes.

The kidnapers leave as quickly as possible. The journey to where they hold their victims can take three or four hours or more. As the speedboat reaches the coast and enters one of the rivers, the pirates make the hostages wear coats with hoods in order to conceal their identity not only from the authorities but, possibly more importantly, from other gangs who might try to steal the hostages from them.

Captivity

The conditions in which seafarers are held by West African kidnapers are poor. Torture or deliberate, prolonged physical maltreatment is rare, although most kidnap victims will suffer the occasional slap or jab with a rifle butt. The major threat comes from the highly unhygienic conditions.

The camps in which hostages are held vary, but most are in very swampy areas some way from any settlements except very small jungle hamlets. The jungle is extremely thick, and the land is low, very muddy and often awash with tidal water. Mosquitoes and other insects are a constant presence, and snakes are commonly seen. Often, hostages are 'housed' in wooden sheds with corrugated roofs, but with gaps between roof and wall. Hostages sleep on mattresses, sometimes with two people to a single mattress. Food is often in short

supply, and consists mostly of rice and noodles, sometimes with eggs. Water is occasionally brought in bottles from shops. The poor hygiene can lead quickly to ill health, with many kidnap victims suffering episodes of diarrhoea and vomiting while in captivity.

Bites from insects are constant and often lead to infections and illness both during captivity and afterwards. One doctor based in the Niger Delta, who conducts medical checks on released hostages, estimated that 60-70% of hostages develop malaria during or after captivity.

Fortunately, seafarers taken captive do normally survive. There has been one documented death during the abduction of crew from vessels in the Gulf of Guinea but, as far as is known, there have been no fatalities arising from the period of captivity of hostages.

Ironically, the unhygienic conditions may act as a brake on the duration of kidnaps. The kidnapers are very aware of the impact of these conditions on their hostages and they likely understand that it is not in their interests to have seriously ill hostages on their hands – it does not suit their business model.

Another factor that may impact on kidnap duration in the Delta is the weather. There are two times of particularly

HFW comment

Q. How many seafarers have been killed, injured or suffered illness as a result of a kidnap?

A. Fortunately, instances of serious physical harm are rare, but the dangers are very real. We have been involved in cases where crew have been shot – in some cases by accident, and in one case a crew member was deliberately stabbed by the pirates in an apparent attempt to assert their authority and instil fear.

The biggest health impacts are often: (i) instances of malaria and other serious ailments among those taken ashore; and (ii) the mental impact of an attack and kidnap, both on those taken from the vessel and also those crew that narrowly escaped being kidnapped and were left on board – it is important not to overlook this latter group who may suffer from anxiety, flashbacks and other mental health issues.

heavy rainfall – the first and longest begins around March, continues until the end of July, and peaks in June. There is a dry period in August followed by the second and shorter rainy season that starts in early September and continues to mid-October, normally peaking at the end of September. There is then a long dry season until early March. Pirate leaders have said to hostages that they wanted to end the kidnap and release them before the heavy rainfall occurs. The kidnapers generally share the conditions in which the hostages are held, and it seems that they are sometimes not keen to hold hostages during sustained rainy periods if they can avoid it. Kidnaps do occur during these periods, but there may be a slight reduction.

Kidnap durations in the region vary, the majority lasting three to four weeks, the longest being around six weeks, and the shortest, two weeks.

Escape has not yet, as far as is known, been an option taken by kidnapped seafarers held in the Niger Delta. The nature of the countryside makes escape an extremely difficult, if not impossible, option. Armed rescue by Nigerian armed forces has occurred in the Delta area on occasion in the past, but it is an approach that puts the hostages in very grave danger. The odds of hostages surviving an armed rescue in such an environment are not good.

Most ex-hostages say that their kidnapers appear less worried by the threat of intervention from the armed forces than from attempts by other criminal gangs to 'steal' the hostages in order to conduct their own negotiation. Kidnap gangs in Nigeria are usually very well armed with automatic rifles, light machine guns and rocket-propelled grenades. Some gangs are well drilled, with regular practices for the actions they would take if an enemy were to attack them by day or night. Hostages are sometimes made to move to new positions at night in order to confuse potential enemies.

Kidnap durations in the region vary, the majority lasting three to four weeks, the longest being around six weeks, and the shortest, two weeks. There are indications that some kidnap gangs are improving their infrastructure to be able to hold more captives for longer. On a recent case, hostages saw that the gang, which was holding them and two other crews in small huts, was building a house which, when constructed, would probably contain 15-20 rooms. Terra Firma has noted an increased confidence and 'market awareness' in some pirate negotiators. Given the lack of law and order in the rural Delta, and the unstable political situation placing heavy demands upon government security forces, it seems unlikely that the kidnapers have much to fear from the Nigerian authorities. The conditions are set for the kidnapers to scale up their business model.

Negotiations, release and recovery

In most parts of the world, it is true to say that the two most dangerous times during a kidnap are the initial abduction, when attackers are scared and hyped up and anticipating possible resistance, and the end, when kidnapers are tired and nervous and expectant. This is,





to a large extent, true in West Africa, although the threat to health, the varied discipline of guards and their access to alcohol and drugs, make captivity in this region a particularly unpredictable affair.

Hostages are usually released into the care of specialist teams who meet the hostages and kidnapers in the creeks of the Delta. This is dangerous and demanding work, and the teams escort the hostages (sometimes with the kidnapers also providing protection) to a place of safety. As soon as the hostages are in a safe place, they are given a medical check-up and all that they need in terms of good food, washing facilities and

new clothes. They are moved to Lagos as soon as they are ready and fit to travel, where they are further looked after before being flown home. Once the hostages reach their home countries, they can be given any aftercare they might need.

Overall, while one should not underplay the discomfort and dangers of being kidnapped from a vessel in the Gulf of Guinea, and the profound effect it has on the lives of hostages and their families. It is important to acknowledge that the vast majority of crew taken hostage in the area do survive the ordeal, and many return to work at sea.

HFW's experience

Q. How can the impact of a kidnap on the crew be best managed?

A. As well as assisting during the period of the kidnap, one important area where a response consultant and lawyer can assist is with the immediate post release. Often, how the crew and their family are supported in the immediate aftermath is a key factor in allowing the crew to recover from their ordeal. The crew should be given the support they need. In addition to dealing with their medical and welfare needs, this also means providing the necessary psychological support together with a clear explanation of the efforts the shipowners went to to secure the crew's release, and listening to the crew's worries and issues. We often recommend a trained

psychologist joins any debrief team. Nevertheless, some may never return to sea.

Often a key concern of the crew is future employment and payment of wages during the period of captivity, as well as compensation for any personal belongings stolen by the pirates. Dealing with these issues promptly and effectively is a good way to minimise any feeling of animosity towards the owners, as well as the crew's suffering. Prudent management of the release, repatriation and post incident support will benefit both crew, shipowners and underwriters. Indeed, in many cases the entire crew have returned to sea with the same company, with the confidence that, having been supported through the toughest of times, the company will continue to act in their best interests.



How companies can prepare for the kidnap of crew off West Africa

Companies should make sure that they are adequately insured:

Hellenic War Risks

Most vessels trading to West Africa will have war risks insurance in place and owners may wish to make enquiries of their war risks insurer as to what response would be provided in the event of a crew kidnapping. Hellenic War Risks, which provides war risks insurance to around 70% of the Greek merchant fleet, has extensive experience of incidents occurring in this region including crew kidnappings. Although its ransom cover is discretionary, the Hellenic's Directors have always responded positively to owners' requests for ransoms to be reimbursed in West African kidnapping cases, as was also the case with the Somali piracy cases the Hellenic incurred from 2008-2012, where it is legal for them to make such a reimbursement. The Hellenic, as a matter of course, has also always appointed specialist kidnap response firms to assist owners in ransom negotiations.

UK War Risks

UK War Risks, also managed by Thomas Miller, is an A-rated specialist war risks insurer, protecting international merchant ships against malicious loss or damage by a third party, anywhere in the world. Members are reassured that if they have an incident – be it a terrorist attack in the Gulf, sabotage off the coast of Africa or damage caused by activists or civil strife, proactive support will be provided, backed by the Managers' expertise in handling such incidents. The Club provides cover to a huge range of vessels. They range from simple tugs to very large LNG carriers, from specialised hydrographic survey ships to international cruise ships. The Club aims to provide world class standards of cover and service at highly competitive rates to all its Members, whether large or small. The Club is a separate entity from the UK P&I Club and has its own Board of Directors, reserves and management team. Applications for entry are welcome, regardless of flag, ownership or management and/or P&I insurer.

UK P&I Club

The UK Club's Loss Prevention department provides practical guidance to Members in relation to piracy in West Africa.

The following are practical tips to Members on how to avoid incidents with West African pirates:

1. The ship should be operating at a heightened state of security throughout, including additional watch-keeping, roving patrols and fire hoses rigged at the railings;



outside doors of the accommodation closed and locked from the inside and temporary barriers erected around the outside stairwells – risk of attack is particularly high when the ship is at anchor or is drifting off a port e.g., close to pilot station or when carrying out Ship-to-Ship (STS) transfer operations.

2. For the purposes of identifying suitable measures of prevention, mitigation and recovery in case of piracy, it is imperative that a ship and voyage-specific risk assessment is performed well in advance as recommended in Section 3 of the Best Management Practices Version 4 (BMP4).

3. Limit the use of lighting at night and reduce the power or turn off the Automatic Identification System (AIS). However, local laws regulating the operation of AIS should be considered and AIS should be reactivated immediately in the event of the ship being attacked.

4. Review and Comply with Guidelines for Owners, Operators and Masters for Protection against Piracy in the Gulf of Guinea Region, to be read in conjunction with BMP4.

5. Careful planning is important and procedures outlined in Section 6 of BMP4 should be followed. Where a vessel is on a regular rotation or at anchorage / conducting STS operations over a prolonged period, particular care should be taken to limit external communications with third parties.

6. Regular reporting to Marine Domain Awareness for Trade – Gulf of Guinea service (MDAT-GoG) while operating within the Voluntary Reporting Area (VRA), which is shown on Admiralty chart Q6114.



7. In the event of any Members considering the use of armed guards, seek the Club's advice, as this is closely regulated by the West African authorities. A number of vessels this year have been detained in Nigeria, simply for having security consultants on board (whether armed or unarmed).

Kidnap response management

An important aspect is to ensure that the company has access to experienced and professional advice on kidnap response management from a company. Owners can make serious mistakes with potentially dire human and financial consequences if they attempt to negotiate with kidnappers on their own, or if they engage advisers who do not have the requisite experience and expertise.

Owners can make serious mistakes with potentially dire human and financial consequences if they attempt to negotiate with kidnappers on their own

Terra Firma provides bespoke training for Owners, shipping management, CSOs and crewmembers going to West Africa. This training focuses on:

- Ensuring that crews understand the risks of kidnap in this region (dispelling wild rumour) but giving them the confidence that, should a kidnap occur, their management is well prepared and professionally advised
- Giving seafarers the tools and information so they know how best to survive the ordeal if they are kidnapped
- Giving shipping companies the information and tools so that they are in the best possible position to respond to a kidnap and to recover from such a crisis with their reputation amongst crews and their standing in the industry enhanced.

Training for crews

It is important that training for crews cover more than just kidnap survival. Crew confidence will be enhanced if, before they depart for their voyage, they are able to discuss the threat with their families accurately and honestly, without allowing the families to fall victim to rumour. They should be able to discuss with their family what the family should do if they are kidnapped, and what it should not do. For example, a wife with children might plan to move to her parents during the duration of a kidnap, so that she and the children get the support they need. Families should be persuaded to continue their normal life as far as possible and to have confidence that the company will do all it can to

negotiate a release of the hostages as soon as possible. Seafarers should persuade their families not to answer any calls from the kidnappers – doing so is likely simply to extend the duration of the kidnap and make the company's negotiation more difficult.

Most released hostages say that one of their biggest concerns during a kidnap was that their family was being looked after and the family should not be too worried about them. Training ensures that seafarers will have confidence that the company will look after the family, and they will take comfort from the knowledge that their family will be coping as best as possible with the stress.

Training seafarers, if they are kidnapped, to behave in a way most likely to ensure their safety and their quick release. For instance, it is always advisable that hostages do not let themselves become involved in negotiations.

Training for companies

Seafarers in Gulf of Guinea waters should be young enough and fit enough, not only for the voyage but also for a possible kidnap. If seafarers take medicines regularly they should carry a stock of medicines on them at all times, even when working on deck. Companies might also consider positioning anti-insect repellent and lightweight mosquito nets on the bridge or on deck so that crew, if taken hostage, can try to take them with them as they are forced to leave the vessel. There is no guarantee that the kidnappers won't steal such items, of course.

With the right training, companies can prepare their crisis management teams and communicators in case of a kidnap. They can ensure that they have up-to-date knowledge and workable policies, and the right people in the right places, both at sea and onshore, to respond in the best possible way. Good preparation often means that a company recovers more quickly and more completely than would otherwise be the case.

HFw's view

Q. How can good preparation and response help a company manage and recover from a kidnap scenario?

A. In addition to the immense physical and mental toll on the kidnapped crew, it is a stressful time for the crew's families and the shipowners. If the shipowner has a tested response procedure and designated 'crisis management' process, and takes appropriate professional advice from those who have handled such cases before, this can help alleviate some of this pressure. Further appropriate 'post incident' management can minimise the financial and operational impact, as well as ensuring the crew are appropriately looked after. Shipowners should also examine their insurance policies very carefully to ensure that the financial expenses and liabilities that they might be exposed to (as above) are covered.

What is likely to happen next?

The threat of kidnap in the Gulf of Guinea is unlikely to disappear or decrease significantly in the next year or so. Indeed, the political situation is likely to worsen before it gets better.

A return to full-scale insurgency, or something approaching it, could increase levels of violence and disruption significantly. There are indications that some of the kidnapers have enough belief in their business model that they are increasing their logistical capacity to take in and hold more hostages, and possibly for longer than is now normally the case. There are also signs that, like the Somali pirates that preceded them, their understanding of the 'kidnap market' is evolving – in other words, they may be able to target their attacks with greater precision and demand higher ransoms.

Shipping companies will need not only to protect their vessels but also to ensure that they can still attract high-quality officers and crews willing to sail in the area. This means that crews must understand but not overestimate the risks, and that they and their families are mentally and physically prepared for an incident. Seafarers should understand how best to look after themselves and their fellows if they are kidnapped. Companies must be able to demonstrate that they take their duty of care seriously, and that they will be able to act professionally if a kidnap does occur.



Nigerian special forces training with US sailors to combat the increasingly violent pirate attacks along the West African coast. The 530 miles (853 kilometres) of Nigerian coastline is a lucrative target for pirates. Energy company vessels crowd the waters off the oil-rich Niger Delta, which provides the US with one of its top sources of crude oil for gasoline. (Credit: AP Photo/Jon Gambrell)



A global team of expert advisors

Terra Firma Risk Management provides crisis management support through a global team of experts who have advised private individuals, aid agencies, governments and companies across all business sectors, including shipping, oil and gas, mining, agriculture, manufacturing, banking, transport, media and retail.

Their team spans six continents with combined experience of more than 200 years and over 650 critical incidents in more than 70 countries worldwide. Team members have a well-matched range of skill-sets and experience with backgrounds ranging from military and police to intelligence and aid work. Terra Firma also has an associate network of more than 25 specialists who provide additional global coverage for a comprehensive spectrum of risk and crisis management services. Terra Firma helps clients to prevent and prepare for crises, respond appropriately to them and ensure a swift recovery.

www.terrafirma-rm.com

UK P&I CLUB

Protecting shipowners and charterers worldwide

One of the world's leading mutual insurers of third party liabilities for ocean-going merchant ships. Insuring over 235 million tons of merchant ships from 50 countries and supporting claims in 350 ports worldwide, the UK P&I Club sets the standard for insurance and claims handling for shipowners and charterers worldwide.

UK P&I Club cover includes third party liability insurance to cover potential claims for damage or compensation in respect of personal injury to (crew members, stevedores, passengers and others), cargo liabilities, loss of personal effects and property (other than cargo), diversion expenses, collision liabilities, wreck liabilities, fines and legal costs.

www.ukpandi.com

UK WAR RISKS

UK War Risks is an A- rated specialist international insurance designed to protect ships of virtually any type or size against loss or malicious damage caused by a third party, anywhere in the world.

Established in 1913, we are UK shipping's biggest mutual war risk insurer and the first club to offer war risks cover internationally on a mutual basis. We insure about 1,000 ships entered by members from around the world.

The Club's cover protects against both the damage or loss caused to Hull and Machinery and P&I liabilities excluded as war risks under those insurances.

www.ukwarrisks.com

HELLENIC WAR RISKS

Covering 70% of the market

Hellenic War Risks Club combines tradition with flexibility and the highest standard of service to provide members of the Greek shipping community with specialist mutual war risks insurance that is second to none. Since our foundation in 1961 we have built a strong reputation so that we now insure approximately 70% of the Greek fleet – about 2,500 ships.

Quality cover against growing piracy risks

Our war risk insurance covers damage and loss caused by the deliberate acts of third parties against a ship. This includes cover for losses caused by war, civil war, revolution and rebellion, or capture, seizure, arrest, restraint or detention. Also covered are claims arising from terrorists, people acting maliciously or from a political motive, piracy or violent theft by people from outside the ship.

www.hellenicwarrisks.com

RISK FOCUS: PAINT

Protecting your asset against the environment



Guarding the value of your asset from corrosion

The primary role of a coating is to protect the asset from the environment it has to work in, in order to provide as long a service life as possible. Not only does corrosion affect service life, it has a real and detrimental effect on costs to the asset owner in terms of service time, down time, performance levels and ultimately, asset value.

41%

Studies show 41% of coating failures are due to poor specification

100^x

Repairing coatings offshore can be up to 100 times the cost of the initial coating

25^{bn}

Worldwide, \$25 billion per annum is spent on marine coatings

\$2^{tr}

Each year, \$2 trillion is spent tackling corrosion

90^{secs}

One tonne of steel rusts every 90 seconds

3%

Faulty paint is the cause of 3% of failures

The coating on a vessel is only a fraction of the thickness of the structural steel, and certainly much less than the cost of the steel, but without paint the asset value would rapidly decrease and working life would be short.

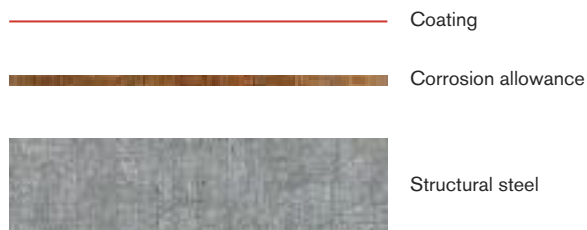

Thickness of coating compared to that of the structural steel

Coating lifetime

The length of service obtained from a coating depends on three main factors:

- How well the coating was applied initially,
- The environment the coating is in, and
- Whether routine maintenance is carried out.

If the environment is not too aggressive and routine maintenance is carried out, then the coating may reasonably be expected to last 15 years and beyond.

In fact, for vessels above 500 gross tonnage, the coatings in ballast tanks are under IMO Performance Standards for Protective Coatings (PSPC) rules, a standard designed to achieve a target coating lifetime of 15 years. More on Water ballast tanks later.

If, on the other hand, there is poor maintenance and the environment is very aggressive, which might be the case in cargo tanks, coating lifetime may be as short as five years.

Coating failure

Prevention is better than cure.

Coating failure or breakdown can occur for a variety of reasons, including structural design, coating specification, poor surface preparation, poor application and poor maintenance. Nothing can be done on structural design, and unless the reader is thinking of buying a new ship, nothing can be done initially on good surface preparation or paint application.

However, putting in place and maintaining routine maintenance is a must.

Initial maintenance may involve little more than regular inspections, but once coating damage or coating breakdown is detected, it should be repaired to prevent corrosion from spreading.

Importance of surface preparation

Good surface preparation is the foundation for any repair. This involves making sure that the prepared surface is clean and has a surface profile. Any contaminants left on the surface e.g. loose rust, oil, grease, dirt, salts, chemicals or dust prior to coating will lead to poor coating performance.

This stage is possibly the most important part of the coating process.

Poor surface preparation can mean either no surface preparation has taken place at all, or that what was attempted was insufficient either in terms of producing a profile for the paint to adhere to, or failure to properly clean the surface before paint application.

Of particular concern when repair is carried out on board is the use of power tools and the tendency to polish the surface, removing the steel profile.

An example of the 'finish' obtained using a conventional hand held tool is shown below. Note the shine on the metal surface on the left compared to the profiled surface on the right.

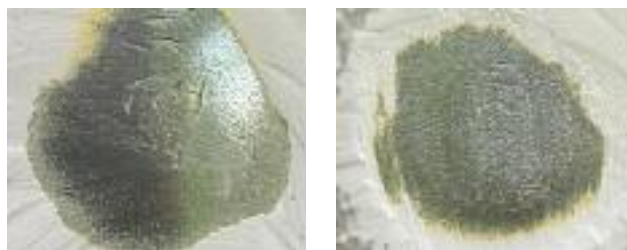

Poor surface preparation is one of the single largest causes of paint failure and could leave your vessel in poor condition, with random and extensive delamination and corrosion.

If poor surface preparation is combined with over application, the result could well be large scale detachment.



Polished mechanical tooling



Repair area with profiled surface ready for painting



Measuring the dry film thickness (dft)

Case study: Coating delamination

Safinah was requested to investigate the cause of paint detachment from a new build vessel.

A review of the paperwork showed that the method of surface preparation involved disk grinding the surface before application of the primer coat.

Examination of the under-surface of the delaminating coating showed two distinct features:

- a. The absence of grinding marks i.e. the surface had not been ground as per instruction, and
- b. the presence of embedded particulate material i.e. paint had been applied over a dirty surface.

Both of the above indicate very little/no surface preparation had taken place.

Technical note:

The fact that the particulate material was embedded into the underside of the coating clearly indicates that the wet paint was applied on top of the material. If the particulate material had been loosely adhering to the paint under-surface, this would indicate that the material had found its way in between the delaminating paint and the underlying substrate after detachment had occurred.

Importance of paint application

Over and under application

Two common causes of coating failure are related to coating thickness. Both over and under application of the protective coating have the potential to cause problems: It is therefore important that the paint manufacturer's guidelines are adhered to with regard to the recommended paint dry film thickness (dft).

Over application of the tank coating at new build can result in paint failure if insufficient time is allowed for the coating to cure properly before loading the first cargo.

If over application is known to have occurred, seek advice. Delay loading your first cargo until you are sure the coating has cured properly. Once the damage has been caused, if it is too extensive for patch repairs, then the coating will need to be replaced.

This is a case where more is not always better.

Another problem that can be related to high dry film thickness is development of cracking. This can happen due to the build-up of stress in the coating, which can be exacerbated by thermal cycling, especially if the cargo has to be heated.

Cracking is a problem that is particularly associated with welds and corners – where there is a change in geometry.

Once the paint has cracked, underfilm corrosion can occur which then results in paint detachment.



Cracking in paint over weld

Under application of the protective coating can, and does, lead to early coating failure with scattered corrosion in areas of under film thickness.

The main tools used to apply paint on board ship are brush and roller.



Scattered corrosion

It is very easy to under apply paint when using either of these tools as the tendency is to spread out the paint too thinly. Even though the required number of coats of paint may well have been applied (as per paint manufacturer's technical data sheet), the repair is likely to be under the recommended scheme film thickness.

This under application means that the repair patch is not able to perform properly as a corrosion barrier. As a consequence, the repair can break down. Note that many of the repair patches shown below show corrosion.



Case Study: Under application of paint

Safinah was approached to carry out a survey of the level of corrosion in an almost one year old water ballast tank. The owner had had two other independent inspections carried out – both had concluded that the extent of breakdown (~1%) was within that allowed by the warranty and therefore could not be claimed for. (Note: greater than 3% rust after one year is a fairly standard warranty kick in point).

It was discussed and agreed that there was little point in repeating a standalone inspection for a third time. However, it was thought that an inspection along with examination of the ship build contract, the paint specification and associated documentation could be beneficial.

The document review identified that 90% of the coated area must be 250microns or greater and the remaining 10% must have a dry film thickness of at least 225microns.

Analysis of the dft readings following the inspection clearly showed a number of areas where the coating thickness fell below the specification minimum.

In fact, 35% of the dft readings were less than 200microns.

A technical claim could therefore be made against the yard.

Technical notes:

- a. the water ballast tank scheme consisted of a single coat where control of dft is more difficult compared to a more standard two coat scheme. Despite the inherent difficulty of applying such a scheme, the yard had agreed to this.
- b. A two coat scheme is standard under PSPC rules.

Maintenance and repair

Some coating breakdown will occur during normal operation and minor repairs do need to be carried out whilst at sea.

Repair should take place at the earliest opportunity.

Depending on the cause and extent of coating failure it may be possible to repair the damage by making patch repairs.

There are two situations, however, where this just is not realistic: if the coating has been over applied i.e. out of specification (and so should have been rejected), or if the surface has not been properly prepared.

In the case of the former, it is possible that over application may result in detachment in other areas over time. In the case of the latter the newly applied paint may suffer from the same adhesion problems as the old paint.

If poor surface preparation is the cause of paint detachment, then the only solution is to remove the paint and start all over again. It pays to get it right first time!



VESSEL AREAS

Contracts by vessel area

Analysis of the marine sector contracts held by Safinah over the last two years indicates the following activity breakdown by vessel area.

Contracts by vessel area %

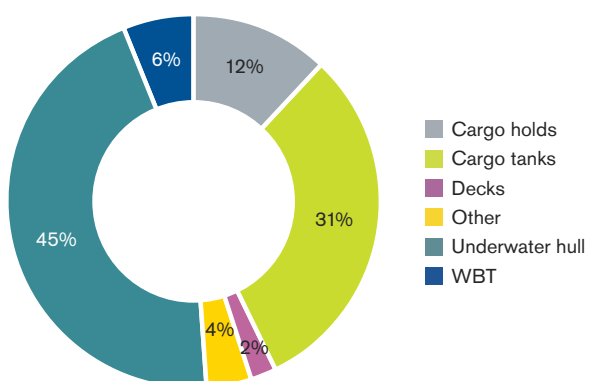

Whilst this is just a snap shot, it is clear from the above that the biggest area of activity with respect to vessel area, is that of the underwater hull, followed by cargo tanks and then cargo holds.

The top three ranking is perhaps not so surprising considering that coating problems in these areas can directly affect revenue generation.

Vessel areas

The cargo carrying spaces on board a vessel primarily require corrosion protection.

Cargo tanks

For chemical and product tankers that require carriage of high purity cargoes, however, another reason for coating the tanks is to preserve the purity of the cargo by preventing contamination from the steel substrate. Uncoated mild steel tanks will corrode when aqueous and water containing cargoes are carried. These tanks would then be unsuitable for carrying higher purity cargoes such as methanol etc.

A good tank lining also speeds up the cleaning process during cargo sequencing.

It is well recognised that as the coating comes towards the end of its lifetime, cargoes move towards the 'dirty' end of the spectrum where coating condition is not an issue. However, these cargoes are not as valuable as the high purity ones, so the tanks need to be kept in as good a condition as possible to maintain this higher revenue.

Poor quality coatings could also result in cargo vetting agents rejecting the tanks for carriage of cargo with potentially huge financial penalties.

Analysis of contracts relating to cargo tank area

Cargo tanks – contract types %

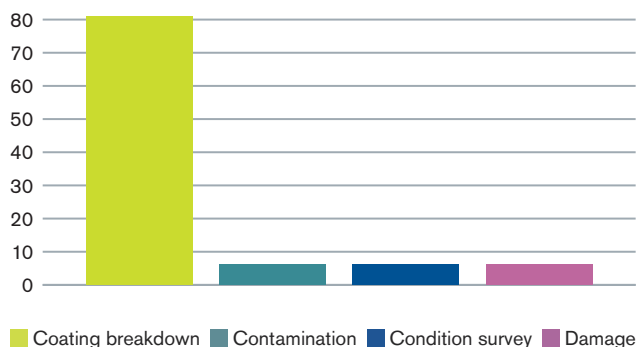

Perhaps not surprisingly, the greatest issue relating to cargo tanks is coating breakdown.

The analysis can be considered to be quite simplistic, as there might be several different causes of breakdown. Nevertheless, regardless of how it has come about, it is clear that coating breakdown is the biggest cause of claims in relation to cargo tanks.

Case Study: Not all rust is as it appears

Safinah were asked to inspect and report on the level of rust present in the cargo tank of a one year old vessel. The photo supplied appeared to show a heavily corroded tank top:



On closer inspection, however, the rust was found to be a surface layer of corroded steel grit. Light abrasion removed the rust to reveal a sound coating underneath.

Corrosion was due to the grit, caught in the pipework during construction, which had subsequently fallen onto the tank top. Far from needing to recoat the cargo tanks, the recommendation was to remove the rust staining and apply a single coat of paint.

Technical note:

Abrading the surface of the paint will leave a roughened surface which is more difficult to clean, and therefore may lead to cargo inspectors deeming the tanks not suitable for certain cargoes, hence the need for a single coat over the top.

Cargo resistance lists

Paint used in product and chemical tankers (tank linings) have associated cargo resistance lists produced by the paint manufacturer that document which cargoes can be safely carried and under what conditions.

Sequencing of cargoes can also be an issue. If this is the case, the cargo resistance list will indicate which cargoes this restriction applies to.

If a material does not appear on the list, it is possible that it is exempt from carriage. In this instance, the paint company concerned should be contacted for clarification.

In addition, certain (more aggressive) cargoes cannot be carried for a certain time period following application of the paint. Carriage of other less harmful cargoes is permitted during this time period.

This period is required for the coating to 'cure', and become more resistant to an aggressive cargo. Trying to circumvent the required period may result in paint failure as the coating may not be resistant enough to prevent attack from a more aggressive cargo.

The length of this initial time period should be identified by discussion with the paint company concerned. After this initial period, it is safe to carry more aggressive cargoes.

Carrying a high purity cargo in the first months after application may not damage the coating, but the coating could damage (contaminate) the cargo!

Post cure

To help obtain better cargo resistance, some tank coatings require a post cure.

This happens when the coating is exposed to a specified temperature for a specified time, usually (but not always) straight after application, before the carriage of any cargo.

Post cure promotes a greater degree of reaction in the coating, which creates a greater cross link density in the coating, which in turn leads to a more resistant coating.

Not all coatings require such a post cure.

Exposing coatings to a post cure if one is not required is not beneficial, and may in fact invalidate the paint warranty.

Conversely, if a coating specifies a post cure, this is what must be done. If not, the coating will remain under cured and therefore less resistant to aggressive cargoes and therefore more prone to damage.

If a post cure is specified but is not carried out, the area should not be accepted.

It is a false assumption that carriage of a heated first cargo will effect satisfactory post cure. It may not.

Cargo holds

For a bulk carrier, the cargo holds are the revenue generating spaces.

The main performance characteristic for cargo hold coatings, aside from corrosion resistance, is its ability to withstand mechanical damage.

Mechanical damage may occur at any stage from loading the cargo, to cargo settlement to unloading.

Much of what is written above about cargo tank linings also applies to cargo hold linings: particularly the need to restrict certain cargoes in the early life of the coating,

Unlike cargo tank linings, however, it is unlikely that there is a cargo resistance list to refer to relating to safe carriage of materials, although the paint company may well recommend avoiding hard angular cargoes initially.

One specific risk of which there is general poor awareness, is the carriage of bulk coals, especially in the early stages of the coating lifetime.

There are two specific problems, both related to softening of the hold coating:

- Some coals contain solvent, which can be absorbed by the coating.
- Coals can exotherm, producing heat.

Once the coating has softened, there is a greater probability of coating damage as the cargo settles and drags the coating down with it.

Analysis of contracts relating to cargo holds

From the problems seen, there is an even split between coating breakdown, application and contamination issues.

Cargo holds – contract types %

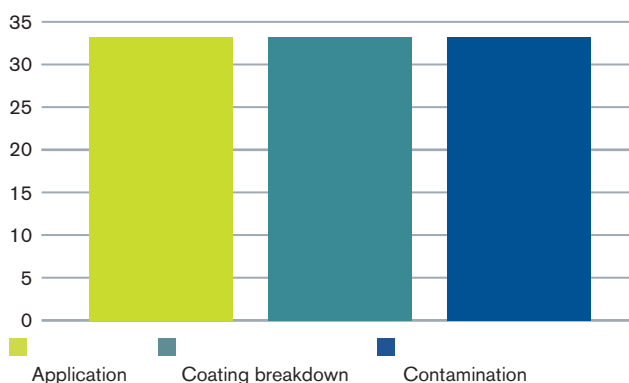

Water ballast tanks and coating technical file

As mentioned previously, the painting of water ballast tanks must comply with the requirements of IMO Performance Standards for Protective Coatings (PSPC).

This means two things:

- a. The coating has to be PSPC compliant, and
- b. A coating technical file should exist on board the vessel.

If considering buying a second-hand vessel over 500GT where:

- a. The building contract was placed on or after 1st July 2008
- b. The keel was laid on or after 1st January 2009
- c. Delivery was on or after 1st July 2012

Then look for the coating technical file.

The coating file is an important document, which contains not only the relevant coating history but also information on surface preparation. This document will help with making future decisions about maintenance and repair.

Hull: Underwater

It is well known that significant performance penalties will be incurred if the underwater area of the hull is not coated to prevent fouling.

As fouling progresses, the friction of the hull through the water increases, resulting in a need for more power to maintain the same speed or a reduction in speed. Both cost the charterer or owner more money.

The first fouling to occur is slime, which is then followed by weed fouling and finally, by hard shell fouling.

It was thought originally that slime fouling only had a 2-4% fuel penalty. However, there is a much greater recognition that slime fouling alone can generate a fuel penalty of up to 15-20%, whilst hard shell fouling can give a fuel penalty of up to, and over, 40%.

Prevention is better than cure.

Types of fouling control

To date, there are three main types of antifouling available on the market:

a. Conventional biocidal antifouling

This category breaks down into several different sub categories including:

- Control depletion polymer (CDP, or ablative), Copper, Zinc or Silyl acrylate self polishing copolymers (SPC), and hybrids of these.
- Such coatings rely on the film surface being continually refreshed to expose active biocide/s to prevent fouling.
- These coatings have different lifetimes, which generally range from 12 to 60 months.

b. Hard, surface cleanable coatings

These do not 'prevent' fouling – but the hardness of the coating is claimed to allow the surface to be regularly scrubbed to remove fouling.



Slime fouling



Weed fouling



Hard calciferous fouling

c. Foul release coatings

The coating has an extremely smooth, low energy elastomeric surface, which makes it difficult for fouling to adhere.

In theory, motion of the vessel through the water will release attached fouling. These coatings are based on silicone chemistry with various additives such as silicone oil, fluoropolymer, etc. Foul release coatings generally do not contain biocides, however, recently, at least one manufacturer has introduced a biocide containing product.



Antifouling selection

It is important that the correct type of antifouling is selected in view of the vessel's operational needs and coating lifetime requirement.

No single antifouling can meet all the operational conditions for a particular vessel. In addition, some of the systems currently on the market are better than others in specific operating conditions.

A vessel with low activity, slow steaming and a risk of extended static periods will have a different antifouling requirement to a vessel which has high activity, is fast steaming, is only static for short periods of time and has a predictable operational profile.

In addition, different areas of the hull are likely to experience different operating conditions, which are also likely to affect, if not the type of antifouling, the thickness of the applied antifouling.

CDPs are typically specified for up to a 30 month service period, whilst hybrid SPC-CDP type coatings and pure SPCs are specified up to 60 months.

There is, of course, a cost associated with each type of antifouling, and all paint companies that offer antifouling will generally offer three levels of anti fouling protection: 'standard', 'premium' and 'ultra'.

Antifouling coating selection might also be affected by where hull cleaning can take place, whether part of the vessel's trading pattern takes it into fresh water, etc. Thus, where the ship trades, as well as how it trades, needs to be carefully considered.

Antifouling pros and cons

The following is not intended to form a comprehensive study of the attributes and drawbacks of the various antifouling, but to present a very short overview. A much more detailed study is required to convey all the various aspects of the different antifouling available on the market.

Whilst each technology type, when used within the limits of its capabilities, provides a good solution, there are also potential draw backs. Some of the issues related to antifouling technology are given below:

Conventional antifouling

Rosin in the CDP type products gives rise to problems with coating integrity as is softened by water absorption and may be damaged more easily than the SPCs on cleaning. This is slightly less of an issue with hybrid coatings, which contain less rosin.

With CDP type coating, biocide release is not linear over the coating lifetime but has a high emission of biocide initially which tails off with time. In addition, due to the mode of action, this coating type has an inherent fuel penalty built in.

A specific draw back with SPCs is the lack of performance in fresh and or brackish water.

Hard cleanable coating

This coating will foul and regular cleaning is required. If regular cleaning is not possible, heavy fouling will occur, increasing the drag on the vessel. This is what your vessel could look like after only 2-3 months, with both weed and barnacle fouling.



Although the hard coating can be cleaned with less apparent damage, the surface will suffer from micro-abrasion during the cleaning process, which will result in a rougher surface compared to the coating straight after application.

Successive cleaning regimes over time will increase this micro roughness, especially if the surface is not polished after scrubbing. This will, in turn, lead to increased fuel costs.

Foul release

The early biocide free version of foul release coatings suffered from slime fouling. Weed and barnacle fouling was also a problem with slow steaming vessels. Faster steaming removed the problems with weed and barnacle fouling, and whilst it helped to keep the slime down, it did not remove the slime completely.

A large fleet owner chose to use market leading foul release technology on its vessels, but due to the presence of slime and the associated increased fuel penalty, the owner decided to remove the foul release coatings and return to biocidal antifouling. So if a vessel is slow moving, the biocide free version of this technology is probably not appropriate for use.



In addition, as the coating is soft, cleaning has to be effected by soft brushes or other non-contact methods, which can take more time and is more expensive than with other more conventional cleaning techniques.

Analysis of contracts relating to underwater hull area

Root cause analysis of contracts involving the underwater hull area is, at first glance, perhaps more surprising than might have been anticipated.

It is clear from the results below that as well as antifouling, there are several other issues relating to this area of the vessel, which are of concern.

Underwater hull – contract types %

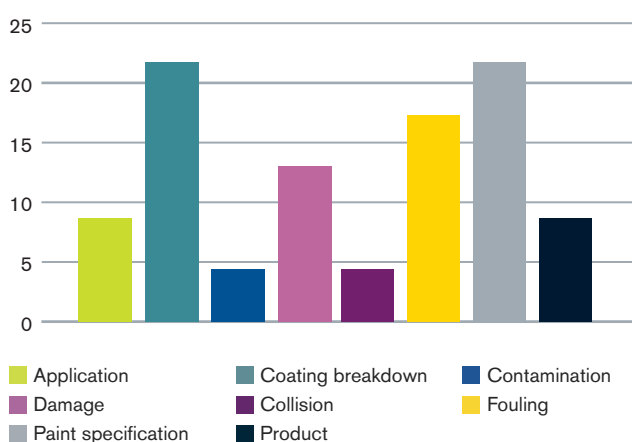

Purchase of a second hand vessel or charter

It is important to realise that the existing antifouling coating would have been selected to work with the trading route / trading pattern of the vessel.

From an antifouling perspective, the biggest risk on buying a second hand vessel, or chartering a vessel, is that the new trading pattern / trading route is different from the vessel's current pattern and route, and as such, the applied antifouling is less suitable. If this is the case, there is a greater risk of problems occurring relating to antifouling performance.

Hull: Above water

This area is mainly an area of aesthetic concern. Coating problems in this area, in general, are twofold and relate to:

- Coating detachment following application outside of the overcoating interval, and
- Mechanical damage to the coating system.

Decks

These are usually protected by a non-skid coating. The paint contains particulate material, which creates a rough surface. It is important to realise that just because the surface is rough it is still possible to slip, especially if oil has been spilt onto it.



SUMMARY

Paint is important in asset protection. It can have a profound effect on both running costs and revenue generation.

To preserve coating life, there are three clear steps:

- a. Select the correct coating scheme
- b. Ensure good surface preparation
- c. Ensure paint application conforms to the paint specification

Concentrate on the key areas that cause the most pain with regard to coatings:

- a. Underwater hull
- b. WBTs
- c. Cargo tanks and cargo holds

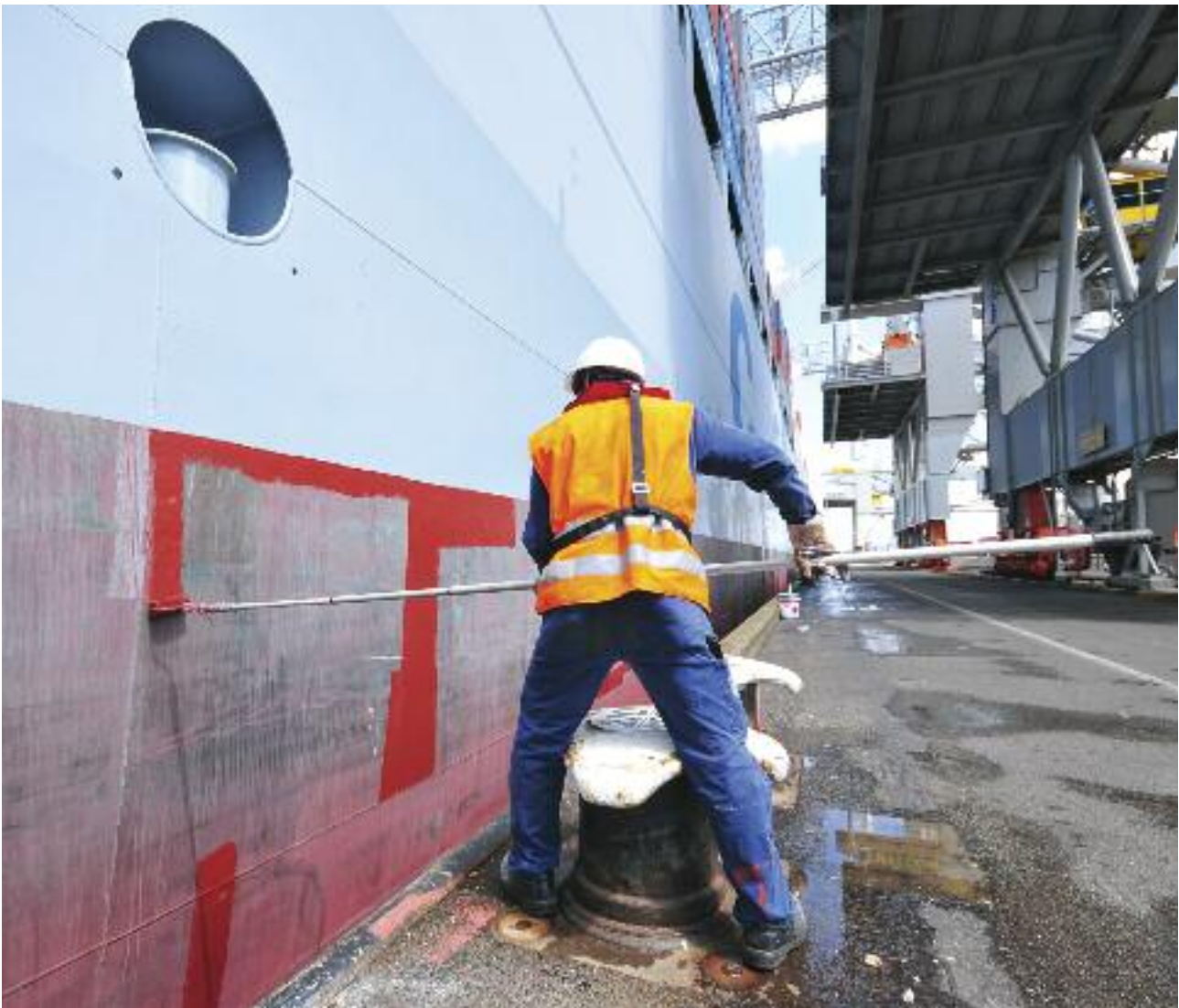



Safinah has a worldwide reputation for creating innovative and effective solutions to all aspects of coating issues, reducing client costs, adding value, improving quality and delivering results.

The in-house team has an unparalleled understanding of all aspects of coatings in the marine, protective, yacht and chemical industries, which enables Safinah to provide authoritative, expert advice on the whole chain of activities supporting your business needs and goals.

UK P&I CLUB



Burgoynes

consulting scientists and engineers

RISK FOCUS: ENGINE ROOM FIRES

The majority of onboard fires originate in the engine room

UK P&I CLUB
IS MANAGED
BY **THOMAS
MILLER**

Reducing the risk of fire in the engine room

Considering the wide range of both sources of fuel and sources of ignition within the engine room, it should come as little surprise that a large proportion of fires onboard ships originate there.

Research coordinated by IMO¹ has indicated that between 30 and 50% of all fires on merchant ships originate in the engine room and 70% of those fires are caused by oil leaks from pressurised systems. Following a major engine room fire it is relatively rare that a ship is able to proceed under her own power. This leads to expensive costs of salvage, towage, repairs, downtime, cancellation of cruises, etc, which can typically run into millions of dollars.

Special attention should be given towards maintaining a clean and tidy engine room where machinery and emergency control equipment are installed and operated in accordance with SOLAS Regulations and IMO Guidelines and that the equipment is routinely serviced and maintained in good working order, and subject to routine testing. IMO MSC.1/Circ. 1321 dated 11 June 2009 entitled "Guidelines for measures to prevent fires in engine rooms and cargo pump-rooms" is especially relevant. If a failure to carry out proper maintenance or to have proper maintenance systems in place is linked to the cause of a fire, the shipowners or managers could face litigation in which allegations of crew negligence and/or unseaworthiness feature.

Except in certain specialist ships, the engine room is invariably a large enclosed space with limited divisions and compartmentation, with restricted access and with only defined walkways between equipment. It is not surprising, therefore, that engine room fires often present very challenging fire fighting conditions where effective first-hand fire fighting may be limited in time for reasons of safety, and where visiting fire parties may have to fight the fire from above when there is little or no visibility. Frequent and realistic fire drills that are tailored to address foreseeable fire scenarios specific to the particular engine room are essential. Moreover, some ship operators choose to engage specialist fire training companies to provide more advanced training aboard their ships.

Fire essentials

All seamen should be aware of the Fire Triangle principle in that if the three elements of an oxidiser, (invariably oxygen from air), a source of fuel and a viable source of ignition come together a fire will result. The basic principles of fire fighting are to "break" one or more sides of the Fire Triangle so as to limit or eliminate the source of fuel and/or the oxidiser. It is also important to keep the fire triangle in mind when

conducting fire risk assessments and implementing fire prevention measures.

In an engine room there is inevitably a plentiful supply of air and very effective ventilation systems. It is helpful, however, to consider in a little more detail the other two elements of the fire triangle; 'sources of ignition' and 'fuels'. An appreciation of the ignition processes will enable engine room personnel to better implement fire risk assessments and fire prevention measures.

Ignition processes

The process of ignition involves the transfer of a sufficient amount of energy to a fuel to initiate a self-sustained combustion reaction. Not all potential sources of ignition will be viable for all types of fuel. For example, whereas a short duration electrical spark is likely to be a viable source of ignition for flammable gases, it will not ignite a liquid fuel unless it is very hot (above its flash point) nor would it ignite most solids. Similarly, although hot particles produced from welding or cutting operations (including angle grinding and disc cutting) are capable of initiating a smouldering fire in fibrous or finely divided solid fuels such as cotton waste, cotton rags, sawdust and cardboard packaging, such sources of ignition are much less likely to ignite solid materials such as timber and plastics. It should

be noted that carelessly discarded smokers' materials (such as cigarettes and matches) provide a potent source of ignition for materials capable of supporting a smouldering fire. Smoking in an engine room should be confined to the control room, where appropriate means of disposing smokers' waste materials should be provided, such as a sand tray or a suitable safety ashtray. On no account should smokers' waste materials be disposed of in a general waste container, such as a waste paper bin.

It will be apparent from these considerations that sources of fuel and potential sources of ignition cannot be considered independently from one another. Possible fuels in an engine room exist in the solid, liquid and gaseous states and their physical and chemical properties will determine the way in which they react to a potential source of ignition and whether that ignition source is viable. The table in Appendix 1 summarises the various types of fuel typically encountered, conditions required to achieve ignition and examples of viable sources of ignition for the fuel. For ease of reference the

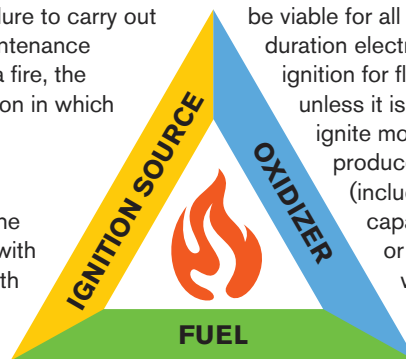

¹ Analysis of Fire Hazard and Safety Requirements of a Sea Vessel Engine Rooms, Adam Charchalis & Stefan Czy, *Journal of KONES Powertrain and Transport*, Vol. 18, No. 2 2011

technical terms shown in italics in the table are explained in a glossary.

Although the table in Appendix 1 provides a useful and quick source of reference, it is helpful to illustrate how a failure to comply with SOLAS Regulations and to provide for effective maintenance and tidiness in an engine room can lead to a serious fire with the potential for loss of life and injury, major financial consequences and unnecessary litigation.

Oil fires

Oil fires are invariably the most serious category of engine room fires. Two ships entered with the Club recently suffered significant engine room fires with remarkable similarities. Both fires originated in the region of the generators when leaking oil sprayed onto hot exhaust surfaces and the subsequent efforts to extinguish the fires were hindered because of a failure to maintain the fire smothering systems correctly and/or a lack of understanding by the crew of the correct method of deploying the systems. In one case, two crew members suffered smoke inhalation injuries and in the other, one died while trying to fight the fire. In both cases significant damage to the engine room occurred resulting in towage and expensive repairs.

Fires can result from a failure to attend to small persistent leaks that can, for example, spread across machinery surfaces to reach parts operating at a high temperature, and from larger leaks that develop suddenly. For example those caused by:

- Loose joints
- Fractured pipes and mechanically damaged (perforated) pipes on both high and low pressure fuel lines
- Bleed cocks on generator fuel filters working loose
- Pipe unions that are over or under tightened
- The fracture of flange bolts if over tightened
- The fracture of cyclically stressed bolts or studs that are under-tightened, such as those securing fuel injector pumps
- The use of unsuitable seals or gaskets which deteriorate due to the effects of heat
- The rupture of high pressure oil and hydraulic fluid hoses due to mechanical damage or aging

Correct maintenance procedures should be strictly adhered to. High pressure pipes should be sheathed and flange joints enclosed where they are in proximity to hot surfaces in order to comply with SOLAS Regulations. Any hot surface shielding should also be effectively maintained.

Hot surface ignition and preventative measures

Oil fires usually occur when oil from a large leak or a smaller but persistent leak comes into contact with a nearby hot surface at a temperature that exceeds the 'minimum auto ignition temperature' (MAIT) of the oil. MAITs of diesel and fuel oil are typically about 250°C, but MAITs as low as 225°C have been reported. Lube oils and hydraulic oils have somewhat higher MAITs. High pressure sprays comprising

fine droplets of oil can ignite immediately on contact with the hot surface, and liquid leaks can ignite after a short period of time sufficient to evaporate the oil and generate a flammable concentration of fuel vapour. Under certain circumstances, such as where flammable concentrations of vapour form in confined spaces, the fire may be preceded by an explosion. Clearly, all oils should remain contained within their intended systems. Oil fires often develop and spread quickly compromising the safety of engine room personnel and, in the case of generators, damaging associated main electrical cabling feeding the switchboard which can lead to a loss of electrical power and, as a result, motive power.

Spray shields should be fitted around flanged joints, flanged bonnets and any other threaded connections in fuel oil piping systems under pressure exceeding 0.18 N/mm² which are located above or near units of high temperature in accordance with SOLAS II-2 Reg. 4.2.2.5.3 and MSC.1/Circ1321. Furthermore, high pressure fuel delivery pipes should be sheathed within jackets capable of containing leaks from pipe failures, the annular spaces of which must be equipped with suitable drainage arrangements to facilitate the rapid drainage of oil to a safe location, such as a drain tank.

It is essential to employ good maintenance systems and engineering principles in order to reduce the risk of oil leaks. This includes, for example:

- attending to minor leaks without delay
- tightening connections to fuel injectors and fuel injection pumps to the correct torque to prevent leakage and/or fatigue fractures caused by cyclical stresses induced by operation of the pump
- maintaining oil leak detection and alarm equipment that can warn of the presence of oil leaks in concealed areas such as a 'hot box' enclosing fuel pumps on some types of generator



Potential route for hot oil vapour to spread from the hot box enclosure to the exhaust enclosure (cladding/covers removed for inspection)

The maintenance of leak detection/alarm equipment is especially important where oil vapour from a leak of hot oil at a temperature above its flashpoint can, for example, migrate from the hot box of a generator, across the engine entablature to exhaust system enclosures where the vapour can auto-ignite

on exhaust components that are otherwise properly shielded from leaks in accordance with the requirements of SOLAS.

Preventing oil leaks is one half of the problem, the other being effective cladding or shielding of hot surfaces so that they do not present a source of ignition if an oil leak occurs. This is possibly the most effective way to prevent Engine Room fires and fairly easy to implement onboard.

It is a SOLAS requirement that surfaces, with temperatures above 220°C that might come into contact with oil as a result of a system failure are properly insulated. Ship's crew should, therefore, appreciate that even a small exposed area of non-insulated hot surface, such as part of a flange joint or an instrument pipe, can be potentially dangerous. The photographs below illustrate examples of defective protection of hot surfaces ranging from a complete failure to clad generator exhausts to the exposure of parts of exhaust systems.



Exhausts completely uninsulated



Exhaust bellows exposed



Small portion of exhaust surface exposed (as arrowed)

While every effort may be made to shield or clad large hot surfaces and their appendages, gaps can exist even in what appears to be well maintained insulation. Turbochargers, in particular, by their complex shape can be particularly challenging to effectively insulate. Therefore, it is sensible practice to carry out routine surface temperature measurements of the critical parts of machinery, especially at bends and flange joints where surface profiles may vary considerably. This can be done effectively by using an Infra-red temperature gun (such as the one illustrated) which is relatively cheap and provides an instantaneous visible reading while being used remotely from the area of interest. It is important to follow the instrument manufacturers' operation instructions otherwise misleading results will be obtained. Some instruments sound an alarm if a measured temperature is outside set limits. It should be noted that higher surfaces temperatures are likely to be reached when there are higher ambient temperatures (such as when the ship is operating in hotter climates) and engines should be under normal or heavy load and up to maximum operating temperature when measurements are made. The instrument can also be used to warn of potential sites of localised electrical overheating on the main electrical switchboard, electrical circuitry and running machinery and for the correct operation of reefer equipment, as will be discussed later.



Infra-red temperature gun. On some instruments a laser beam pinpoints the target surface of interest, making for precise measurements and accurate temperature profiling. Slightly more expensive instruments provide a heat map image of the area of interest.



"Hot spot" due to missing insulation

Alternatively, surveys can be carried out by using more expensive thermal imaging equipment which provides a clear image of the surface temperature profile as illustrated in the example below, where the thermal image is compared with the visible light image.



IR001153.IS2-NO1 Auxiliary engine



Visible light image

Main image markers

Name	Temperature	Emissivity
Hot	318.1°C	0.95

Images courtesy of SVL Singapore Services

As a result of such surveys, it was estimated that around 80% of ships checked had exposed areas in excess of the 220°C SOLAS requirement. Recent checks by the Club's Risk Assessors using an Infra-red temperature gun suggest that this figure may not be exaggerated.

Indicator cocks are another potential source of ignition. IMO MSC.1/Circ. 1321 Para 1.1.5 recommends that "Exposed indicator cocks should be insulated in order to cover the high temperature surface."

Again, an IR temperature gun can be used to assess the fire ignition risk of uncovered indicator cocks.



Uncovered indicator cock with exposed temperature above SOLAS limit

Lagging fires

If mineral oils (fuel oil, diesel oil, lube oil) soak into lagging on pipe work operating at a temperature above about 150°C there is a risk that the oil will oxidise slowly within the matrix of the lagging and eventually ignite spontaneously, causing the lagging to disintegrate and oil from a persistent leak to ignite. This process can take many hours, and there may be little external warning of the imminent danger until smoke appears shortly before the fire becomes visible. It is essential, therefore, that oil leaks are attended to promptly and that permanent repairs, including the replacement of oily lagging, are made correctly rather than resorting to makeshift solutions.

Risk of 'spontaneous ignition'

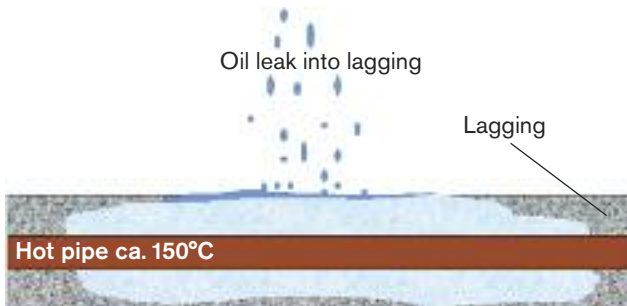

Tank save-alls

Dirty oil tanks and purifier save-alls present a fire hazard, both from being at a risk of ignition and providing a means of spreading a fire. It is essential to keep drain lines clear and prevent oil accumulation. Oil residues are likely to be at a temperature below their flash points and, therefore, not directly ignitable. However, fibrous solids such as cotton waste and rags partially immersed in the oil can function as a wick. The 'wick' may be ignited by contact with a welding spark or a smouldering source, such as a carelessly discarded cigarette, leading to a smouldering fire that eventually undergoes transition to flame. The oil feeds into the wick to sustain the fire and the surrounding oil layer is raised to a temperature at which flame can spread across the oil surface causing the fire to develop. The failure of tank valves and level gauges directly exposed to the save-all fire becomes possible.

Self-closing valves are fitted between the lower end of an oil tank and its gauge glass. The purpose of these valves is to isolate the tank gauge glass from the tank. In normal operation they should be shut and only opened to check the tank contents after which they should be shut automatically under spring pressure or counter balance gravity.

The UK Club's ship inspectors regularly find that various methods are used to keep these valves permanently in the open position. Chocks of wood, pieces of wire and purpose made clamps are often seen to be used to for this purpose. This is dangerous practice. If a gauge glass breaks in a fire the entire contents of the tank will leak into the burning area, escalating the fire.



Self-closing gauge glass valve gagged with wire



Self-closing gauge glass held open with string

Solid fuels

As summarised in the Table at Appendix 1, solid fuels typically encountered in an engine room include:

- cellulosic materials, such as constructional timber, cardboard packaging, sawdust, cotton waste and rags, and
- plastic materials, of which there are two main types: thermosetting plastics, which maintain their form and rigidity when exposed to high temperatures, and

thermoplastics, which tend to melt and drip when exposed to high temperatures.

The potential for cellulosic materials to smoulder and to be susceptible to ignition by small ignition sources such as sparks produced by hot work and carelessly discarded smokers' materials is often overlooked. Smouldering fires can develop slowly, sometimes in concealed spaces, and may not be discovered until several hours later after the transition from smouldering to flaming combustion has occurred. Although the presence of constructional timber in an engine room is unusual, it should be noted that timber insulated from its surroundings and in contact with a hot surface at only a moderately elevated temperature (i.e. above about 120°C) can under certain circumstances ignite after many days. Any constructional timber should, therefore, be well separated from or insulated from hot surfaces.

Angle grinding and disc cutting operations should be included in the 'hot work' category because, although the size of incandescent particles produced is generally very much smaller than those produced by welding and flame cutting operations, a stream of grinding or disc cutting sparks landing in the same area of a solid fuel can be sufficient to initiate a smouldering fire. Frictional heating of the work piece may also act as an ignition source, e.g. of oil residues on its surface.



A stream of sparks from disc cutting

It is essential that engine room workshops and stores are kept clean and tidy and that smoking is strictly prohibited. In the stores, packaging materials should be kept to a minimum and cardboard cartons should be stored clear of light fittings. In the workshop, floor areas and work surfaces should be clear of all combustible waste, particularly cellulosic materials susceptible to smouldering combustion. This is especially important when hot work is carried out behind welding curtains to prevent the spread of stray sparks. Cotton waste and rags should be kept in a bin fitted with a lid and bales of cotton waste and rags stored in a metal cabinet.

Oil soaked rags have been known to "self heat" and combust spontaneously so, until they can properly be disposed of, should be kept in a steel container with a lid.

Hot work outside the workshop should be the subject of a hot-work permit system. It should be noted that sparks from

welding and flame cutting operations take time to cool to a temperature at which they are no longer incandescing, can be projected considerable distances, e.g. more than 10 metres, can travel horizontally by bouncing and can fall through gaps. Careful consideration must be given to the removal of all combustible materials within range of the hot work and the use of proprietary welding blankets or curtains to cover materials that cannot be moved and to cover any gaps to prevent incandescing particles falling into unprotected areas. If there is a possibility of a flammable atmosphere being present in the area where hot work is planned, gas testing of the atmosphere within range of flying sparks must be carried out before and frequently during the work out by a competent person using an explosimeter that has been calibrated and serviced in accordance with the instrument manufacturers' guidelines. Hot work should only be permitted if the reading on the explosimeter registers 10% LEL or less both before and during the hot work.

Another potential source of ignition is an electrical lead light whose unprotected bulb and its filament are perfectly capable of starting a fire.

Gaseous fuels

A relatively small number of ships utilise gas as a fuel for propulsion. Gaseous fuels typically encountered in an engine room are acetylene and propane. Oxygen, although not a fuel, will also be present for oxy-gas welding and flame cutting operations. These gases are supplied in colour coded cylinders with gas specific regulators and flashback arrestors. Gas cylinders should not be stored in the engine room. Oxygen and acetylene cylinders should be stored upright in separate ventilated steel compartments above the weather deck, separated from other compartments. From there, the gases at low pressure are distributed via flashback arrestors and steel pipes to outlet stations in the engine room fitted with stop valves which should be kept closed when not in use. Alternatively, gases can be distributed at high pressure to outlet stations fitted with flashback arrestors, regulators and stop valves. Where only portable oxy-gas welding or cutting equipment is available this should be secured upright when not in use in designated ventilated compartments on or above the weather deck.

Flexible hoses designated for use with oxy-gas equipment, colour coded blue for oxygen, orange for propane and red for acetylene must be used. When laid out in an engine room the hoses should not be kinked or pass over sharp surfaces that could cause damage. When a cutting or welding torch is not in use the gas supplies must be isolated at the shut off valves. Under no circumstances should hoses be folded over to temporarily isolate a gas supply to the torch. Hoses should be subjected to frequent inspection and damaged hoses should be replaced in accordance with manufacturers' recommendations.

All equipment must be properly maintained and leak tight. The leakage of acetylene into enclosed spaces causes an explosion and fire risk. Acetylene is an extremely reactive gas and, when mixed with air in certain proportions can detonate. In a previous accident a pressurised acetylene flexible hose

was leaking close to the air intake of the starting air compressor, resulting in flammable mixture being created in the air receiver. Subsequently, when the air was used to start a generator, a series of serious explosions occurred, fracturing pipe work and other equipment. Similarly, oxygen leaks must be prevented and special care must be taken to exclude even traces of grease in oxygen handling equipment, such as regulators. Combustible materials that may ordinarily not be easily ignited will ignite readily and burn violently in oxygen enriched atmospheres.

Electrical fires

Electrical circuits are distributed from the main electrical switchboard to all parts of the ship via sub-distribution boards. Cables are protected against overload by using fuses or circuit breakers. Fuses and circuit breakers are rated specifically for the size of the cable and the load they are protecting and it is dangerous to replace these with protection devices of a higher rating. All circuits should be correctly labelled at the main switchboard and the sub-distribution boards. Where cable routings have been altered it is essential to make permanent changes to circuit labelling at the fuse or circuit breaker board and to updated electrical drawings. Temporary labels marked on adhesive tape or written on adhesive paper to cover over the original label can deteriorate and detach, leading to confusion over which circuit is energised.

Spaces behind switchboards should be clear of packaging materials and the floor area should not be used for storage purposes. Such practices increase the risk of a serious fire developing there. The inside of switchboard casings should also be kept clear of dust, dirt and other flammable materials.

In a normal circuit there should be no added resistance introduced at junction points, such as where cables are screwed to terminal connectors or where plugs are inserted into sockets, or as a result of thinning of conductors in a cable caused by mechanical damage. Unfortunately this is not always the case. A failure to ensure that terminal connections are correctly made and tight can cause a point of local resistance, unwanted heating and a fire hazard ('resistance heating'). Such defects are usually self-worsening as a result of thermal cycling and an accelerated formation of surface oxide which increases the resistance thus further reducing the effectiveness of the terminal contact. It is important, therefore, to not only ensure that terminal connections are correctly made, but also to inspect these whenever the opportunity arises.

Routine inspections of busbar connections on the main electrical switchboard can be made by using an Infra-red temperature gun of the type to which reference was made earlier. However, such inspections will not always be a useful indicator of incipient resistance heating faults at sub-circuit or equipment terminal connections. Whereas the incipient fault may not be apparent at the time of the Infra-red temperature measurement, it could self-worsen exponentially with time. Nevertheless, such measurements are to be encouraged generally, even though the results should be interpreted with caution. There are also companies that specialise in undertaking such surveys.

The insulation on cable conductors and motor windings can deteriorate over time. A breakdown in cable insulation can lead to stray electrical currents and ultimate short-circuit arcing in a cable. This can be a highly energetic event that can readily melt plastics and may completely evaporate metal contacts and cable conductors resulting in the explosive ejection of molten metal providing a source of ignition. A breakdown in the insulation of motor windings can be a source of localised heating and fire. It is essential, therefore, that a programme of routine insulation resistance testing of cables and other equipment is maintained, and be aware that cable insulation can deteriorate from exposure to UV light.

Arc flash incidents can occur where engine room personnel work carelessly on live equipment and cause a short circuit with a tool. No matter how well a person may be trained, distractions, weariness, pressure to restore power, or over-confidence can cause an electrical worker to bypass safety procedures, work unprotected, drop a tool or make contact between energised conductors. This may not only lead to serious injury or death, but also provide a source of ignition for a fire.



Arc flash incident



PPE to guard against the effects of arc flash

The contacts of switching mechanisms, such as in contactors, can become eroded and this may cause contacts to stick closed or provide a source of resistance heating. Routine inspections of such equipment may not be practicable, especially in respect of small compact devices. However, the equipment should be repaired or replaced if there is evidence that the contacts fail to open and close correctly or if signs of localised heating are discovered.

The confluence of electrical cables in distribution boards necessitates a large number of terminal connections to both cable conductors and overload protection devices such as circuit breakers. Inspections of terminal connections and, ideally temperature measurements of the same made by using an Infra-red temperature gun, should form part of shipboard inspection and maintenance programmes. Where multi-stranded electrical conductors are connected to a terminal care should be taken to ensure that there are no stray strands that could inadvertently make contact with another part of the installation. It should be established that all switchgear is clean and circuit breakers are in good condition. Fire stopping around cable glands should be in good condition to minimise the risk of a fire spreading from the distribution board to surrounding areas.



Cables entering a distribution board through fire stopped openings in the casing

Larger electrical cables are often steel braided or steel wire armoured so that combustible insulation is not exposed and the risk of flame spread is minimal. Even though cable insulation is invariably flame retarded to lessen the risk of ignition and flame spread, groups of cables fixed to a cable tray can spread flame, especially when exposed to an external source of fire, such as a fire on an auxiliary generator.



Damage caused by the spread of fire along cable trays after being exposed to a fire at a lower level of the engine room.



Fire spread along cable trays away from an auxiliary generator where the fire originated

Scavenge fires

Fires occasionally occur in the scavenge space of two stroke diesel engines. The fuel for such fires is normally a mixture of lubricating oil, unburned fuel and carbon deposits which form an oily sludge. It has been observed that heavy deposits typically accumulate before a fire occurs, normally due to engine deficiencies such as: excessive cylinder liner and/or piston ring wear (sometimes caused by poor quality fuel); broken piston rings; poor combustion; and improper timing. The deposits are normally ignited by the blow-by of hot combustion products between the piston and liners, but mechanical abrasion between components represents an alternative ignition source.

To prevent scavenge fires there should be an adequate maintenance regime for the main engine, and in particular for: the cylinder liner; piston components; piston rod stuffing boxes; fuel system and cylinder lubrication system. Furthermore, scavenge spaces, and the drain pockets therein, should also be regularly inspected and cleaned. If present, the cause of an excessive build-up of oily deposits in the scavenge space should be investigated and rectified. With the engine in operation, scavenge drains should also be regularly checked to ensure that they do not become restricted or blocked.

Crew members should be trained in the actions to be taken in the event of a scavenge fire and in the use of the local scavenge fire extinguishing medium/system provided aboard the ships. In the event of a serious scavenge fire crew members should be aware that: boundary cooling may be necessary; that they should stand clear of scavenge space relief valves in case of explosion; and that the scavenge space should not be opened for inspection until it has adequately cooled.

Soot fires in exhaust gas boilers/economisers

Diesel engines, particularly those running on heavy fuel oil, inevitably generate soot that will be deposited on exhaust gas boiler tubes. If the soot is dry it is unlikely to ignite when

exposed to exhaust gas temperatures normally encountered in the economiser, which are typically 220-260°C.

The rate of deposition of soot can be greater when diesel engines are operated on light load, i.e. when slow running or manoeuvring for an extended period of time, due to unfavourable combustion conditions and low exhaust gas velocities. When operating on light load, the possibility also exists that there will be a carryover of cylinder lubricating oil and/or unburned fuel with the exhaust gas, which can result in the oil particles mixing with the soot, to form a so-called 'sticky soot' that has a greater propensity to deposit on boiler tubes. It has been reported² that oil mixing with the soot can significantly reduce the ignition temperature of the soot deposits and that in the extreme spontaneous ignition can occur below 150°C, i.e. at temperatures below those encountered under normal operating conditions. It is for the reasons explained above that soot fires are more common following manoeuvring or operation on low load. Such fires can be severe and develop to the extent that boiler tubes become damaged, resulting in a loss of integrity. Water escaping from the damaged tubes can break down to release hydrogen that sustains and increases the severity of the fire leading to extensive damage to the boiler.

Soot fires in exhaust gas boilers can be averted by regular soot blowing of the exhaust gas boiler tubes (ideally using automatic soot blowers), particularly after slow running or manoeuvring. In such a scenario it is recommended that soot blowing should be carried out prior to increasing engine power or shutting down the engine. Water washing may also be carried out if permitted by the manufacturer.

The risk of a soot fire can also be reduced by starting the boiler water circulation pump in advance of the main engine and this should not be shut down until after proper cooling of the tubes, for periods of time recommended by the manufacturer. Furthermore, any defects that may lead to excessive engine smoke generation should be promptly addressed.

Crew members should be trained in the actions to be taken in the event of a soot fire in an exhaust gas boiler, taking account of the guidance given by equipment manufacturers and the facilities onboard the ship. In this regard, when discovering a small soot fire the principal objective should be to act promptly to prevent it developing to the extent that there is a loss of integrity of the boiler tubes. It should also be noted that should the fire develop to this stage, then extreme care should be exercised when using water to fight the fire as this may worsen the situation unless copious quantities of water are applied to the heart of the fire.

Boilers and incinerators

Oil-fired combustion systems installed on boilers and incinerators can be a source of fires and onboard controls and interlocks should be in good working order and never overridden. The risk of fire and explosion incidents occurring can be minimised by implementing effective inspection and maintenance procedures.

² Soot deposits and Fires in Exhaust Gas Boilers, MAN Diesel & Turbo, September 2014

Visual inspections

These should be carried out by a trained and competent engineer on each watch to ensure that:

- The flame picture within the combustion chamber is correct in order to confirm that the oil is atomising properly and combustion characteristics are correct. Incorrect atomisation of the fuel can lead to an accumulation of unburnt fuel in the combustion chamber.
- Pipework both supplying and forming part of the burner equipment is leak-free. Note that fine oil sprays are sometimes less conspicuous than drips and weeps from leaking joints.
- Flexible fuel hoses are in a sound condition, showing no signs of physical damage, corrosion or abrasion.
- There are no unusual noises associated with the operation of combustion air fans and oil pumps.
- Operating pressures and temperatures are correct.
- Drip trays and save-alls are clean and dry.

Routine inspection, testing and maintenance should be carried out in accordance with manufacturers' guidelines and any onboard planned maintenance procedures. This includes control equipment on incinerator waste oil feed tanks. A recent explosion in a waste oil feed tank resulted from a failure to maintain the liquid level sensors and interlocks which allowed the oil level to fall below the thermostat resulting in a loss of temperature control. The heater elements also became partially exposed, which vaporised some of the oil and ignited the vapour.

Large quantities of solid waste for the incinerator should not be allowed to accumulate. Fire detection and automatic fire extinguishing systems for waste storage compartments should be in good working order.

Fire safety systems

Chapter II-2 of the SOLAS (1974) Regulations and their amendments set out the requirements for the provision and maintenance of fire detection, fire suppression, fire prevention and means of escape in case of fire. For ships, the keels of which were laid on or after 1 July 2002, engineering specifications for these fire safety systems are set out in the International Code for Fire Safety Systems (FSS Code). The lives of crew members and their ability to carry out effective fire fighting to minimise damage is dependent on the operability of these systems and familiarity of crew members with them. Delays in the detection of a fire and in the implementation of fire fighting will inevitably be critical.

Fire detection

This is normally achieved by smoke or heat detectors. Ideally these should be of the addressable type so that the precise location of the fire can be determined from the fire alarm panel. Under no circumstances should detectors be covered, e.g. whilst conducting hot work in the vicinity. The testing of fire detection and alarm systems should be carried out in

accordance with IMO circular MSC.1/Circ. 1432, May 2012. Weekly tests should be carried out to determine that all fire detection and fire alarm control panel indicators are functioning by operating the lamp indicator/test switch. A sample of detectors and manual call points should be tested on a monthly basis so that all detectors will have been tested within five years, and all detectors should have been visually examined within a one year period to ensure that they are not damaged and that they have not been tampered with. In unmanned or temporarily unmanned machinery spaces additional fire detection equipment will be required in accordance with SOLAS II-1.

Fire suppression

In their 2015 annual report, the USCG identified that the greatest deficiency onboard ships (21%) was the fire fighting appliances.

Types of safety deficiencies

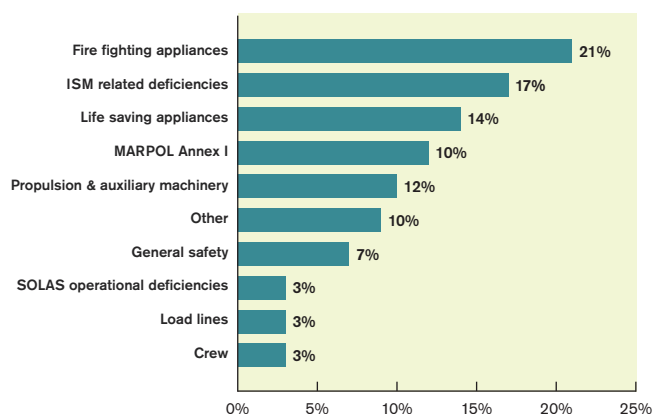

The UK Club's Risk Assessors also frequently note defects in this area. Fire hydrant caps are often found to be difficult to remove by hand (requiring the use of a spanner) and hydrant valves are found to be leaking. Leaking hydrants in an engine room may be tightened with a wheel key and this may render them inoperable by hand in the event of a fire. It is recommended that the high risk threat of engine room fires is recognised and that ship's crew pay particular attention to training and the care, maintenance and correct operation of all fire fighting equipment.



Hydrant cap difficult to remove, and valve leaking



Obstructed FFE

A possible reason for the substandard condition of fire fighting equipment is that it is infrequently used during fire drills. It is clearly not advisable to rig and discharge fire hoses in the engine room, but hydrant caps and valves, fire hoses and nozzles, and fire dampers can still be checked and tested and the correct positioning and inventory of portable extinguishers can be confirmed. In the case of fire dampers it is not sufficient to test them for correct operation alone. It is important to inspect the condition of each damper to ensure that it is not corroded and that it seals properly with the frame of the opening against which it closes. The exclusion of a ready supply of air to the engine room will be crucial in starving the fire of oxygen and maintaining the effectiveness of total flooding gas fire suppression systems that have been activated.

Fixed fire suppression systems

In both the recent generator fires discussed earlier, fire fighting attempts were hindered by the ineffectiveness of the fire smothering system because of a lack of understanding of its correct method of deployment and a lack of proper maintenance.

In the first, it is thought that the Chief Engineer did not operate the CO₂ system release mechanism correctly and, as a result, only one cylinder (of 43) was discharged which had a negligible effect on the fire. It is possible that he released a cylinder from the main bank of cylinders instead of a pilot cylinder in the mistaken belief that this would trigger the release of the requisite number of cylinders.

In the other, it was found that of the two banks of halon cylinders, one bank had only been partially released and the other bank had not been released at all. It is noted that halon systems should generally have been decommissioned since December 2003.

During another unrelated engine room fire incident (which started when fuel sprayed onto a hot, unprotected exhaust system) it was thought by the crew that the CO₂ had been released when, in fact, it had not. During a subsequent inspection of the CO₂ system, it was accidentally activated and three crew members in the engine room were fortunate to escape with their lives.

Fixed fire suppression systems should not be considered as a "last resort" as they are possibly the most effective and least dangerous method of fire fighting. Indeed, it should be appreciated that these systems are most effective if used promptly. As such, the crew must be familiar with their operation. Clearly, CO₂, high expansion foam, high-pressure water mist and water sprinkler systems should not be activated during fire drills. Ship's staff must, however, be trained on and be familiar with their operation so that they can be correctly deployed and with minimum delay. Fire mains can, however, be tested by pressurising with designated fire pumps, including the emergency fire pump, and connecting fire hoses on deck to ensure that the correct water jets are provided. Crew members should be trained in the use of all fire pumps, as it is possible that the crew members most familiar with the fire pumps could be incapacitated or unavailable when a fire occurs.

Instructions to operate CO₂ systems can be complicated and valuable time will be wasted if it is necessary to read these for the first time in order to activate the system. Fire drills should include rehearsing the sequence in which the necessary operations should be carried out to activate the systems, including the importance of stopping fans and closing engine room ventilation dampers. In one instance, an electrician was instructed to activate the CO₂ system but, with no previous knowledge or training, did so incorrectly.





After a CO₂ system has been activated in accordance with operating instructions, it is prudent to check that the pilot bottles have operated and the requisite number of cylinders has discharged. This can be done by visually inspecting the cylinder release mechanisms to determine that they are in the activated position. It is important to bear in mind, however, that leaks from the activated system can occur which may reduce the oxygen concentration in the cylinder storage room. For this reason crew members should be ready to perform enclosed space entry procedures with self-contained breathing apparatus sets when undertaking such checks. Automatic fire suppression systems, such as local application high pressure water mist systems, can be used in the auto or manual modes. However, in order for such systems to be most effective they should be left in the auto-mode and the smoke and flame detection systems that trigger their operation should be active and fully operational. Valves in pipework feeding these systems should be kept open.

Limiting fire spread

Engine rooms are separated from other parts of the ship, such as the accommodation, by fire resisting divisions constructed in accordance with SOLAS II-2 to contain the fire and limit the risk of fire spread. Openings in these divisions, such as engine room access doors, are fitted with self-closing devices. Similar arrangements are found within the engine room for the purpose of subdividing it into compartments. Fire doors are, however, regularly found to not fully close automatically or are tied / wedged in the open position.



Fire door failing to close



Fire door tied open

This creates an unnecessary hazard because it provides a route by means of which smoke and fire can spread to adjacent compartments and accommodation areas can quickly fill with smoke preventing safe egress, resulting in fatalities. Moreover, this may also prevent fire parties from preparing and taking up the most favourable strategic positions or accessing fire lockers etc. It may be necessary to evacuate an engine room before there is sufficient time to close engine room access doors that are held open. This is likely to render the CO₂ system as ineffective.



Fire door tied open

All fire doors on a ship are important, but when the high risk of Engine Room fires is considered, Engine Room fire doors should receive special attention.

The particular importance of the fire doors between the Engine Room and Steering Gear Compartment should also be emphasised. These are very frequently found to be tied in the open position.



Steering gear fire doors tied open

Not only do these doors prevent fire spread from the engine room into the steering gear compartment, they would prevent wastage of CO₂ in the event that the total flooding system has been released. The calculated volume of the CO₂ required to flood the engine room does not include the volume of the steering gear compartment which means that the concentration of CO₂ in the engine room would be less than required in the event that the door was left open.

Combustion products and/or CO₂ escaping into the steering gear compartment would make it difficult to access, leading to delays in priming and/or starting the emergency fire pump if it is located there, as is often the case. Open fire doors would also hinder any fire-fighting / rescue attempts from the steering gear compartment which, typically being at a lower level than other engine room access doors, is an obvious place from which to tackle engine room fires, which was the case in one of the aforementioned incidents. The dead crew member was later recovered from here. During the other incident, the steering gear compartment was used as the principal escape route.

The UK P&I Club has already issued a Technical Bulletin No. 25/2007 (Steering Gear Compartment Fire Doors) on this topic, and it should be added that the door from the steering gear compartment onto deck should be able to be unlocked from both sides.

Escape routes and escape doors

In the UK Club Technical Bulletin No. 39/2012 (Escape from Engine Rooms) it is suggested that arrows are painted on the deck plates pointing to the nearest escape route. This good practice is commonly seen on UK P&I Club ships, but sometimes the arrows could be laid out more clearly. The photographs show excellent arrows leading to the escape trunk, but none to the steering gear compartment which is an alternative escape route.



Well marked escape route arrows



Poorly marked escape route and door



Well marked door

Technical Bulletin No. 39/2007 also recommends that the exit doors are clearly highlighted. In both the above photographs, it can be seen that white painted doors do not stand out well against white painted bulkheads. Doors painted with “tiger stripes” or marked with retro reflective tape are far more obvious.

The best escape route from an engine room fire will depend on the location of the fire and its severity and so it is, therefore, difficult to generalise. However, careful thought should be given when marking emergency escape routes and these should not be confused with normal exit routes. In a fire situation, the safest escape route may not be via the internal ladders leading up to the accommodation exits, but sideways (or even downwards) via the escape trunk, the steering gear room or other “safe” areas such as shaft tunnels and side passageways.



Arrows leading away from exit door

Technical Bulletin No. 39/2007 also points out that even though engine room staff might believe that they know their way around blindfold, others (for example visitors and newly-joined crew) may not. Furthermore, smoke is very disorientating. A crew member who suffered smoke inhalation injuries during a recent fire became disorientated in the thick smoke was an Oiler who would be expected to have been very familiar with the engine room layout. He was fortunate to survive whereas an AB who was wearing a breathing apparatus in order to fight the fire died in the process. The air bottles of his breathing apparatus were found to be empty and it was assumed that he became disorientated and was unable to find his way out of the smoke filled engine room, the layout of which was less familiar to him than engine room personnel. For this reason, the composition of fire fighting parties should be considered carefully.

Emergency shut-down equipment

In the event of a fire in the engine room it may be necessary to activate emergency shut-down equipment, often from remote stations, with the principal objective of isolating fuel and air – two sides of the fire triangle. This includes stopping ventilation fans, closing ventilation dampers, stopping fuel pumps and tripping oil tank quick closing valves.

Quick closing valves

The UK Club Technical Bulletin No. 36 deals with Quick Closing Valves. These are fitted to the outlets of lubricating and fuel oil storage, settling and service tanks within the machinery space, boiler room and the emergency generator room. These spring loaded valves may be operated locally or remotely by pull wires, hydraulic systems or compressed air.

The majority of serious engine room fires are fuelled by oil. In the event of fire it is essential that sources of fuel from storage and service tanks are rapidly isolated to prevent a continuous flow to a point of leakage, extending the fire both in severity and time. This can be achieved by the operation of quick closing valves, either locally or remotely, leaving only residual oil in pipelines as the feed for a source of leakage.

It is suggested that regular operation of these valves not only familiarises staff with the process, but helps ensure that the valves do not become seized or stuck. Just because the valve appears to be shut does not necessarily mean that it is properly seated and oil tight and this should be checked whenever practicable.

Quick closing valves will not shut if, as sometimes noted, they are tied or wedged in the open position. This is an unnecessary and highly dangerous practice.



Quick closing valve held open with a steel wedge



Quick closing valve held open with a stop

SUMMARY

Engine room fires are one of the most common fires on ships owing to the presence of a wide range of sources of fuel, sources of ignition and running machinery. An extended period of time onboard a ship without a fire incident can lead to complacency and a failure to prioritise fire prevention measures and simulated fire incident practices.

The risk of a fire can be substantially reduced by:

- Maintaining a clean and tidy engine room.
- Ensuring that machinery and emergency control equipment are installed and operating in accordance with SOLAS Regulations and IMO Guidelines and they are routinely serviced and maintained in good working order, and subject to routine testing.
- Ensuring that hot surfaces are shielded and clad in accordance with SOLAS requirements.
- Ensuring that emergency equipment such as oil tank quick closing valves, fire pumps, remote stop systems and fire fighting apparatus are generally armed and immediately ready for use.
- Ensure that automatic closing mechanisms on all fire doors within and at the boundaries of the engine room are working correctly.
- Ensure that ventilation closures are operable, are visually free of corrosion and provide a reasonable seal.
- Carry out routine inspections of electrical equipment to include (i) the insulation resistance of cables and equipment where appropriate (such as motor windings) and (ii) visual inspections of terminal connections and Infra-red temperature gun measurements.
- Ensure that portable fire fighting appliances are correctly positioned and serviced.
- Ensure that all hydrant outlets are accessible, and operable.
- Ensure that fixed fire fighting installations are properly maintained and armed.
- Carry out routine fire drills to address different simulated fire incidents in various parts of the engine room.
- Ensure that responsible persons are fully familiar with the correct operating sequences for the CO₂ and foam fire fighting systems so that valuable time is not wasted.
- Ensure that oxygen, acetylene and propane cylinders are safely stowed in a ventilated compartment above deck and provided with correct regulators, flash back arrestors and shut-off valves. Ensure that cylinder valves are isolated when systems are not in use.
- Ensure that escape routes are clearly marked by using deck plate arrows and that exit doors are readily visible.

DO

- Ensure that oil leaks are attended to promptly by effecting permanent repairs.
- Ensure that where required by SOLAS II-2, oil pipes are sleeved and pipe joints are shielded, and that all oil pipework is adequately supported in correct fitting pipe clamps.
- Carry out routine temperature measurements of shielded or clad hot surfaces to ensure that even small parts are not exposed. This can be achieved by using an Infra-red temperature gun.
- Ensure that oil leak alarms on generators are in good operating order.
- Ensure that engine room stores are tidy and that packaging material is not close to light fittings.
- Ensure that engine room workshops are kept tidy, the floor area is clear of combustible materials and that cotton waste or rags are stored in a metal bin fitted with a lid or in metal cupboards.
- Ensure that drain lines in oil tank save-alls are clear and the save-alls are kept clean and free of solid materials such as cotton waste or rags.
- Ensure that oil tank gauge glass self-closing cocks are unrestricted and operating correctly.
- Ensure that oil tank quick closing valves are properly armed and that they are tested regularly.
- Ensure that fire detection equipment is properly maintained and operable.

DO NOT

- Allow smoking in the engine room other than in the control room where suitable arrangements are provided for the disposal of waste smokers' material.
- Make temporary repairs to oil containing pipe work.
- Work on pressurised fuel systems.
- Secure open self-closing oil tank gauge glasses.
- Secure open by external means oil tank quick closing valves.
- Secure open fire doors within and at the boundaries of the engine room.
- Carry out hot-work in the engine room without a correctly completed, properly considered permit to work and until all necessary hot work precautions are in place.

APPENDIX 1

Sources of fuel typically encountered in an engine room, the conditions necessary for ignition, and viable sources of ignition

Fuel	Conditions for ignition	Viable sources of ignition
<p>Cellulosic material, e.g. cardboard; waste paper; cotton waste; cotton rags; sawdust. NB this type of fuel can be set smouldering leading to a small fire that may be inconspicuous (e.g. in a concealed space) that later undergoes transition to flame.</p>	<p>Contact with a flame or hot surface for a sufficient length of time or exposure to radiated heat of sufficient intensity to reach its <i>firepoint temperature</i>, or exposure to a small hot surface (e.g. a spark or contact with an unguarded light bulb) for a sufficient length of time to initiate smouldering combustion.</p>	<p>Naked flames; flame cutting; disc cutting; hot surfaces such as parts of exhausts, hot flues, economisers etc; live residues from smokers' materials e.g. cigarette ends; contact with the unguarded bulb of an inspection lamp; exposure to radiant heat from a halogen lamp.</p>
<p>Solid timber. Timber structures, timber cladding etc can also be set smouldering in inconspicuous spaces leading to a fire that later undergoes transition to flame.</p>	<p>Contact with a flame or hot surface for a sufficient length of time or exposure to radiated heat of sufficient intensity to reach its <i>firepoint temperature</i>.</p>	<p>Naked flames; hot surfaces such as parts of exhausts, hot flues, economisers etc; sparks produced by hot work such as welding, flame cutting; close contact with localised electrical overheating due to a poor electrical connection or defective component; exposure to radiant heat from a halogen lamp.</p>
<p>Thermosetting plastics Such as are used for electrical fittings and mouldings and for thermal/acoustic insulation e.g. rigid polyurethane foam. Can form a char when exposed to high temperatures which can smoulder before later undergoing transition to flame or ignite other combustible materials with which it is in contact.</p>	<p>Contact with a flame or hot surface for a sufficient length of time or exposure to radiated heat of sufficient intensity to reach its <i>firepoint temperature</i>.</p>	<p>Naked flames; hot surfaces such as parts of exhausts, hot flues, economisers etc; close contact with localised electrical overheating due to a poor electrical connection or defective component; exposure to radiant heat from a halogen lamp.</p>
<p>Thermoplastic materials, such as polystyrene foam used as packaging material or thermal insulation on refrigeration pipework. These materials tend to melt and shrink away from a heat source.</p>	<p>Contact with a flame or hot surface for a sufficient length of time or exposure to radiated heat of sufficient intensity to reach its <i>firepoint temperature</i>.</p>	<p>Naked flames; hot surfaces such as parts of exhausts, hot flues, economisers etc; exposure to radiant heat from a halogen lamp. Because thermoplastics tend to shrink away from heat sources this makes them more resistant to ignition.</p>
<p>Liquids stored and used at temperatures below their flashpoint, such as gasoil, diesel oil, lubricating oil and hydraulic oil.</p>	<ol style="list-style-type: none"> Contact with a source of heat that raises the liquid to at least its flashpoint temperature so that the vapour derived from the liquid becomes ignitable by an external ignition source such as a spark or naked flame. Contact with a source of heat that evaporates the liquid and which is at a temperature that exceeds the <i>minimum autoignition temperature (MAIT)</i> of the vapour causing the vapour to ignite spontaneously, i.e ignition results from exposure of the vapour to the hot surface alone, without the need for an external ignition source such as a spark. Leakage of the liquid fuel into lagging insulating a hot surface at a temperature above about 150°C where the liquid can catch fire by <i>spontaneous ignition</i>. There can be many hours delay between the accumulation of sufficient oil in the lagging and ignition. 	<ol style="list-style-type: none"> Exposed parts of engine exhausts, turbochargers, economisers, steam pipes, hot flues and thermal fluid pipes at a temperature exceeding the <i>flashpoint temperature</i> of the liquid in the presence of an adjacent external source of ignition such as a spark or naked flame. Exposed engine exhausts, boiler combustion chambers and thermal fluid pipes at a temperature exceeding the <i>minimum autoignition temperature (MAIT)</i> of the vapour derived from the liquid. Exhausts, turbochargers, boiler casings, steam pipes etc lagged with Rockwool or glass fibre insulation.

Fuel	Conditions for ignition	Viable sources of ignition
Liquids stored and used at temperatures above their flashpoint , such as heavy and intermediate fuel oils.	<ol style="list-style-type: none"> 1. Exposure of the fuel vapour to a spark or naked flame. 2. Contact with a surface at a temperature that exceeds the <i>minimum autoignition temperature (MAIT)</i> of the vapour causing the vapour to ignite spontaneously, i.e ignition results from exposure of the vapour to the hot surface alone, without the need for an external ignition source such as a spark. 3. Leakage of the liquid fuel into lagging insulating a hot surface at a temperature above about 150°C where the liquid can catch fire by <i>spontaneous ignition</i>. There can be many hours delay between the accumulation of sufficient oil in the lagging and ignition. 	<ol style="list-style-type: none"> 1. Naked flames; electrical discharges, sparks from hot work. 2. Exposed parts of engine exhausts, turbochargers, boiler combustion chambers and thermal fluid pipes at a temperature exceeding the <i>minimum autoignition temperature (MAIT)</i> of the vapour. 3. Exhausts, turbochargers, economisers, boiler casings, steam pipes etc lagged with Rockwool or glass fibre insulation.
Gases , such as lpg and acetylene	<ol style="list-style-type: none"> 1. Exposure of the gas to an electrical spark or naked flame. 2. Contact with a surface at a temperature that exceeds the <i>minimum autoignition temperature (MAIT)</i> of the gas causing the gas to ignite spontaneously, i.e ignition results from exposure of the vapour to the hot surface alone, without the need for an external ignition source such as a spark. 	<ol style="list-style-type: none"> 1. Electrical discharges, sparks from hot work. 2. Exposed parts of engine exhausts, turbochargers, boiler combustion chambers and thermal fluid pipes at a temperature exceeding the <i>minimum autoignition temperature (MAIT)</i> of the gas.

GLOSSARY OF TERMS

Flashpoint

Combustible liquids are classified according to their flashpoint. This is the lowest temperature at which the concentration of the vapour in air above the liquid surface becomes flammable and capable of being ignited by an external source such as a naked flame or an electric spark. Flashpoints are normally determined according to the 'closed cup' method by using an apparatus where the test liquid is contained in a small cup with a lid to minimise loss of vapour. The liquid is heated slowly and a small flame is introduced to the vapour space at frequent intervals until the vapour ignites in a flash. In practical situations involving an open pool of liquid, however, sustained burning at the surface of a liquid at its flashpoint is unlikely to occur until its temperature is raised further (typically by 5-20°C for hydrocarbon fuels) to the 'firepoint' temperature. This is because the rate of evaporation of the liquid at the flashpoint is not fast enough to support sustained flaming.

Firepoint

Visible flame at the surface of a burning liquid or solid fuel involves the combustion of vapour generated from the fuel. The vapour concentration in air at the surface of the fuel must exceed a minimum concentration before it is ignitable and can burn freely. The *firepoint* of a liquid is the temperature at which the rate of evaporation is sufficient to sustain this minimum concentration. In the case of solids, the *firepoint* is the temperature at which the surface of the solid breaks down to release a stream of volatiles (vapours) at a concentration sufficient to support a flame. The volatiles can be ignited by contact with a flame or some other source of ignition such as a spark. If the rate of heating of the solid surface is high enough, such as can happen when it is exposed to the radiant heat from a nearby halogen lamp, the volatiles can *'autoignite'*; i.e. the vapour/air mixture bursts into flame without the need for an external source of ignition such as a spark.

Minimum autoignition temperature, MAIT

When a flammable gas or vapour/air mixture is raised to a sufficiently high temperature it can ignite spontaneously, i.e. without an external source of ignition such as a spark or naked flame. This is known as the *autoignition* temperature. The *autoignition* temperature is, however, very sensitive to the geometry of the surface that is providing the heating. For reasons of safety we are interested in knowing the *minimum autoignition temperature (MAIT)* of a fuel. As spherical flasks provide the most favourable conditions for ignition, these are invariably used to determine the *MAIT*. Such favourable geometries are not commonly found in an engine room. However, for reasons of safety, it is prudent assume that if the temperature of any surface (irrespective of its geometry or size) exceeds the reported *MAIT* of a fuel, a fire will occur. The *MAIT* for diesel has been reported to be as low as about 220°C, whereas the *MAIT* for fuel oils, lube oils and hydraulic oils is somewhat higher (above about 250°C). It is understandable, therefore, that SOLAS requires all high temperature surfaces to be reduced by insulation to below 220°C.

Spontaneous ignition

When certain bulk solids and solids contaminated with certain liquids are exposed to moderately elevated temperatures, they react with oxygen to liberate heat. This causes the temperature of the material to rise further by a process of self-heating and can eventually lead to ignition. Examples of spontaneous ignition are fires caused by the leak of mineral oils (e.g. diesel oil and lube oil) into lagging on pipes operating at a temperature in excess of about 150°C, the ignition of oil and soot residues in an economiser and the self heating of a pile of waste rags contaminated with oxidisable oils.

Burgoynes

consulting scientists and engineers

Burgoynes is an international Partnership specialising in the forensic investigation of fires, explosions and other major incidents. The Partnership was founded in 1968 by the late Emeritus Professor Jack Burgoyne. Being the first organisation of its type in the UK, the eight offices around the country provide a comprehensive national service, with a worldwide presence provided by its offices in Singapore, Hong Kong and Dubai.

The expert forensic scientists and engineers advise clients across the legal, insurance and commercial sectors including shipowners and managers, P&I clubs, hull & machinery underwriters, cargo underwriters, shippers and professional salvors. Comprehensive reports are prepared to assist clients in resolving legal and contractual issues, and have been used in both court and arbitration proceedings in the UK and other jurisdictions around the world.

Investigations have been carried out into the causes of several thousand fires and explosions involving all types of marine ship. Advice has been prepared on the prevention of such incidents, and assistance has been provided in the management and extinguishment of fires still in progress. Advice is routinely given on the properties, carriage and handling of dangerous cargoes.

For further details, please visit their website:
www.burgoynes.com

UK P&I CLUB



RISK FOCUS: HATCH COVERS

UK P&I CLUB
IS MANAGED
BY **THOMAS
MILLER**

Are the ships' hatch covers weathertight?

This seemingly simple but important question is what surveyors, whether acting on behalf of P&I clubs, shippers, charterers or courts have to answer on a regular basis. Whilst the answer should be invariably “Yes” or “No”, the way to come to the right conclusion is not so easy and requires a good understanding of hatch covers, their operation and tightness as well as industry requirements.

This brochure has been designed to help those involved in inspecting, testing and evaluating the weathertight integrity of hatch covers in making well informed decisions, and assist owners and shipboard personnel in maintaining their hatch covers and closing appliances in line with good industry practice and standards.



History

In 1929, the first ever steel hatch covers were introduced and patented by the brothers Robert and Joseph MacGregor (MacGregor & Company) and in 1941 the prototype of the single pull hatch covers was made available on the market and further developed.

Following the Second World War, another interesting evolution took place in that we saw the transition of the traditional types of ships (mainly general cargo ships, tankers and passenger vessels) into a wide variety of dedicated ships types such as e.g. bulkers, reefer, roro, container and multipurpose vessels. Each of these ship types required their own hatch cover design, in order to accommodate their respective cargoes.

Over the last decades, the major challenges and hurdles that had to be overcome were those associated with jumboizing. With the rapid increase in the number of larger ocean going vessels, there was a need to engineer solutions that allowed larger, heavier hatch covers to remain weathertight while at sea. Furthermore, properly engineered and well-designed hatch covers should allow for quick and safe operation whilst being lean on maintenance without compromising reliability.



Different plies of tarpaulins used for making hatch covers weathertight



Tarpaulin type hatch covers, properly battened down and ready for going to sea

With safety and delivering the cargo in good condition being the main prerequisites when it comes to hatch covers, it will be seen that proper and well planned maintenance is of paramount importance in order to ensure that hatch covers perform well under harsh conditions.

The International Convention on Load Lines and Weathertightness

Like most equipment found on board, hatch covers are also subject to certain rules and regulations. One of the most important conventions that deals with hatch covers and hatch cover safety, is the International Convention on Load Lines (ICLL).



Evidence of leakage in way of the hatch cover cross joints

The main goal of the ICLL is to “Establish uniform principles and rules with respect to the limits to which ships on international voyages may be loaded having regard to the need for safeguarding life and property at sea”.

We further note that ICLL states “The load line shall never be submerged at any time when the ship puts to sea, during the voyage or on arrival”.

The idea behind the above statements is that a ship should never be overloaded as this would reduce the vessel's freeboard which is crucial for the ship's safety.

The ICLL also states that “the vessel's hatch covers need to be weathertight”. This means that in any sea conditions, water should not enter the ships hold, as this would add additional weight to the vessel and could lead to overloading (submerging of the loadline) which would put the ship in danger. For this reason, and under the ICLL, it is a prerequisite that the ship's hatch covers are weathertight in order to prevent water entry into the ship's holds.

Although it is quite common to mix the terms “weathertightness” and “watertightness”, they have different meanings, which may give rise to some confusion. According to ICLL, watertight means “...capable of preventing the passage of water through the structure in either direction with a proper margin of resistance under the pressure due to the maximum head of water which it might have to sustain.”

Finally, the ICLL mentions “*The means of securing weathertightness shall be to the satisfaction of the Administration. The arrangements shall ensure that the tightness can be maintained in any sea condition, and for this purpose, tests for tightness shall be required at the initial survey, and may be required at periodical surveys and at annual inspections or at more frequent intervals*” (Reg.16-4). The latter statement refers to the involvement of the Administrations, the need to maintain tightness when at sea, and the need for regular testing.

It is clear that, in order to comply with the ICLL, hatch cover design requires careful consideration at the design stage.

Manufacture and design

The stringent requirement under the ICLL that “...*tightness can be maintained in any sea condition...*”, makes designing and manufacturing of hatch covers a challenge. Building hatch covers that are able to keep water out in any sea condition requires a good knowledge and understanding of how hatch covers will behave (both in port and at sea) and issues such as hull, coaming, panel deflections and movements, exposure to elements (effects of temperature, wind, sea [water] loads, cargo) and type of ship and trade.

Hatch cover design

In order to design hatch covers that comply with ICLL, and meet with customer’s demands and expectations, different issues have to be considered, such as:

- Hatch way dimensions
- Available deck space for stowing the panels
- Available stowage height for panels
- Required coaming height
- Required extent of opening
- Type of operation (opening and actuating mechanisms)
- Available power
- Required opening/closing time
- Degree of automation (available crew)
- Repair possibilities (availability of shore specialists/ship’s crew repair skills, spare parts)
- Carriage of cargo on hatch covers

- Required degree of tightness (weathertight/reduced weathertight and non-weathertight)
- Cost (min – max scantling, steel price)
- Required/Max. panel weight (ship’s gear, shore gear, power and rubber packing line compression)
- Construction type (open web, double skin) and required fittings (cleats, packing)
- Trading pattern (warm/cold, tropical rain showers/speed of closing)

In addition, the design has to be such that the cost (for manufacture, installation and maintenance) is low and that the in-service life (without failures) is long.

Hatch covers and tightness

Apart from being designed and developed by specialists, compliance with the ICLL needs to be further confirmed by the Administration/Classification Societies in the form of type approval.

In order to understand the difficulties related to design, it is important to know that ships are subject to different deformations when in port and at sea. These distortions are brought about by loaded/empty/ballast conditions as well as flexing and twisting of the hull as a result of wave action, which all have an influence on the hull form and eventually, the hatch covers.

It is therefore important to understand the relationship between hatch covers and the ship.

In the first place, one has to think of a ship as a steel box, and in this context, it is useful to compare a ship with a box of cookies. Such a box will be quite rigid as long as the lid (comparable to the deck of a ship) is on. However, once the lid is removed, the box becomes very flexible as it has lost part of its structural integrity. Whilst on a ship, the deck is not completely removed, big openings (hatch ways) are created, which in turn leads to the structure of the ship becoming more flexible. An extreme example of this is the open hatch-type ship, which has large hatch openings and therefore, less deck space than an ordinary design.

In order to maintain the vessels weathertightness, it is necessary to cover up these openings in the deck.





Open hatch design

Whilst a certain degree of flexibility of the ship's hull is necessary, the hatch covers will generally have a different type of construction and will be more rigid than the ship onto which they are fitted.

This difference is responsible for relative movements between the ship and hatch covers at coaming level. Therefore, it is necessary to equip the hatch covers with a flexible medium in way of the coaming interface to compensate for these relative movements. This flexible medium is generally known as the hatch cover packing rubber, which is available in different forms and sizes depending on the type of ship or service.

Water ingress into a ship poses a safety and financial risk. Minimising this risk can be achieved by designing hatch covers that are able to withstand the rigours of an ocean voyage. Whilst packing rubber plays an important role in making hatch covers weathertight, achieving weathertightness is not possible with the packing rubber alone. Although well maintained packing rubbers will already reduce the risk for water ingress significantly, further risk reduction calls for additional safety barriers.

In a weathertight hatch cover system, the following three safety barriers will be required:

- A strong steel structure
- Packing rubber (flexible seal with design compression to compensate for known movements)
- Drain and collect any incoming water that passes through the joint in extreme conditions

By carefully considering and including the above safety barriers in a hatch design, it will be possible to comply with the ICLL requirements, as the combined action of these safety barriers will prevent, even in the worst conditions at sea, significant quantities of water entering the ship's holds, and as such, contribute to ship, crew and cargo safety.

Ship movements

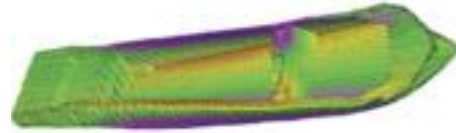

Showing ship deflections

Relative movements will exert loads and forces on the component parts of the hatch covers, and as such, the above movements can be divided into three main components:

- Vertical forces (also referred to as F_z)
- Longitudinal forces (also referred to as F_x)
- Transversal forces (also referred to as F_y)

Key parts

In a weathertight hatch cover system, various key parts need to work in unison in order to ensure that weathertightness is achieved and can be maintained throughout the voyage.

Details about the design and wear limits or tolerances of these key parts can be found in the manufacturer's manual, and it is worthwhile to include specific details of these key parts in the hatch cover checklist as this will facilitate inspections. In order to gain a better understanding of the most important key parts, some additional information is provided below:

Packing rubbers

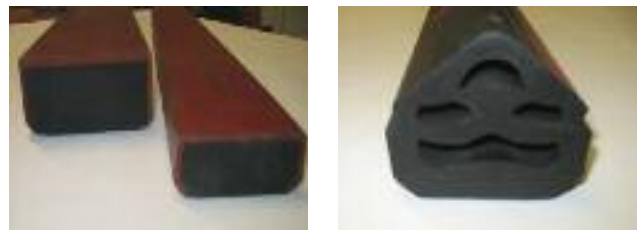

Different types of packing rubbers (from left to right: Sponge rubber, CAT or Sliding seal and Flex seal)



Different shapes of packing rubbers (from left to right: linear rubber, end piece with solid nosing, flat corner and vertical corner)

Hatch covers span a huge opening and the relative movement between the covers and the coaming is such that a compression seal is needed to achieve and maintain a tight seal between the covers and the compression bar. A compression seal/rubber is designed to be compressed up to a specific depth. This will allow the rubber to compress and relax, and as such, absorb relative movements between the hatch covers and coaming compression bar.

As coaming deflections (both transversal and longitudinal deflection) will cause continuous interaction between the rubber and compression bar, packing rubbers are subject to wear and tear. Furthermore, and throughout the voyage, packing rubbers are exposed to heat, cold, sunlight, cargo (abrasive/chemicals), chlorides, etc, which also affect the packing rubber's in-service life.

It is clear that developing packing rubbers that are fit for duty and retain their flexibility throughout their in-service life is not easy. Such rubbers also require proper and correct maintenance in line with manufacturer's guidelines.

Packing rubbers are designed to be compressed to a certain depth, which is generally referred to as the design compression (*rule of thumb for estimating the design compression of ordinary box-type packing rubbers is as follows: Design compression = 25% of the nominal thickness of the packing rubber*). Depending on the type of rubber packing, design compression will generally be in the range of 4-20mm, and this is either specified in the maker's manual or indicated in the drawings (although not always easy to find).

Rubber size: 70 x 40

Design compression: 25% of thickness = 10mm

Discard criteria: 50% of design compression = 5mm



Overcompression of the packing rubber will result in permanent damage over time. This will become apparent in the form of a set groove in the impact area between the packing rubber and compression bar, as shown in the following images.



Deep permanent groove in packing rubber as a result of overcompression. Also note the off-centre permanent imprint

The best comparison one can make is with an elastic band. This can be gently stretched to a certain limit, and when released, it will regain its original size and length almost immediately. However, when "overstretched", plastic deformation will occur and the elastic band will no longer return to its original length and the return process will also take more time (Hook's law). Overcompressed rubber will therefore lose its elastic properties and flexibility (and hence, its capacity to compensate for relative movements).

Apart from identifying the need for regaining its original shape, a second element that is equally important can now be identified, i.e. time. Not only should the rubber be able to compensate for the relative movements between the panels and the coaming, it is also necessary that this reaction is instantaneous as otherwise a temporary gap might be created between the packing rubber and the compression bar in the time that is needed by the packing rubber to adapt to the new situation, which could give rise to water ingress when waves are breaking over the deck and hatches. In order to allow it to regain its original shape quickly, the packing rubber will need to have a certain compression force (e.g. the compression force of a normal 90x50 packing rubber can be in the range of 9000N/m).

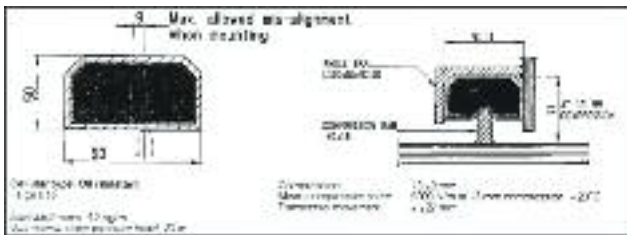

Considerable force is required to bring the panels down to the rubber packing design compression, but on most modern ships, the weight of the panels alone is sufficient to achieve the required design compression.

Whilst the original design will cater for some slight variations in compression (due to waviness of coaming or compression bar), the criteria for discarding a packing rubber is, as a rule of thumb, generally considered to be equal to 50% of the design compression. So if the design compression is 12mm, it is recommended to discard the rubber packing when the permanent imprint has reached a depth of 6mm. When renewing the rubber packing, it is important to find out what caused the permanent set to develop. Whilst several years are needed to achieve the discard limit as a result of normal wear and tear, improperly maintained and adjusted hatch covers will generally cause accelerated wear and deep permanent imprint. In the latter case, replacing the rubber packing alone will not solve the problem and finding the root cause of the problem is necessary to ensure that repairs will be efficient.

Whenever packing rubbers need replacing, it is tempting to look for alternative (cheaper) products but, when doing so, it is extremely important to ensure that not only the dimensions are compatible, but also that the alternative product will meet with the required performance criteria, which may not always be the case (in many cases, it is true to say that “a cheap packing rubber is not good and a good packing rubber is not cheap”).

Bearing pads

Bearing pads are supporting pads that comprise of two parts. One part is fixed on the panels and the other part is welded on the coaming. Bearing pads work in the vertical plane (Fz). They provide steel to steel contact between the panels and the coaming, and, as such, prevent the panels from sitting too low on the coaming, which would cause overcompression of the packing rubber, or panels from being pushed down under weather loads causing the cleats to be come disengaged.



They also prevent other structural parts like wheels and axles from taking up the load acting on the panels. Furthermore, bearing pads contribute to proper alignment/adjustment of the panels and transfer the load into the deck structure. Finally, in case of wear, they can relatively easily be repaired and restored to their original height.

Knowing that there is a relative movement between the hatch covers and the coaming, bearing pads should also allow for some movement between the mating halves of the bearing pad system. To prevent wear and corrosion that would prevent sliding action between the mating halves, compatible steel needs to be used. Bearing pads are available in different sizes and materials, and their wear will depend on their position and loads. This means that not all bearing pads will wear down to the same extent simultaneously, and require regular checking/inspection to determine if allowable wear limits have been exceeded and if repairs or replacement are necessary. The use of low-friction material is recommended to allow for smooth movement between panels and coaming, and to avoid the disturbing noise that is created by friction between ordinary steel to steel pads.

Bearing pads are fine pieces of engineering and replacing them with non-original spares or non-compatible steel could result in serious problems. Far too often bearing pads are replaced or repaired by the ship’s crew with only one thing in mind, i.e. restoring the height of the bearing pads, whereby the correct size and use of appropriate material for the mating surfaces is overlooked. For bearing pad adjustment, it is





Improper repairs to bearing pad and a crack developing in the hatch panel side plating due to advanced bearing pad wear

strongly recommended that manufacturers or specialists are called in for advice.

On hatch covers that are equipped with bearing pads, an operational clearance in range of 10-15 mm will generally be present between the panel side lower edge and coaming. The exact distance should be checked with the manual and clearly noted on inspection sheets as it is one of the first indicators of bearing pad wear down.



Operational clearance between the lower edge of the panel side plating and the coaming table

Whilst many people think that bearing pads take up all the loads that are acting on the hatch covers, it should be borne in mind that the rubber packing has a compression force that takes up part of this load as well.

Locators

Locators guide the panel in its correct closing position and ensure that panels are kept properly positioned during the voyage. Correct positioning is important to avoid problems with opening systems, wheels, hinges, cross joint drains, securing mechanisms, etc, and slight wear on the locators in one place might well result in significant loss of compression or improper positioning at another place. Therefore, locator wear should also be regularly monitored.



Properly maintained and adjusted locator

More recent designs of locators have replaceable mating surfaces and allow for the use of shim plates, which facilitates installation and adjustment in case of wear down.



Excessive wear on locator

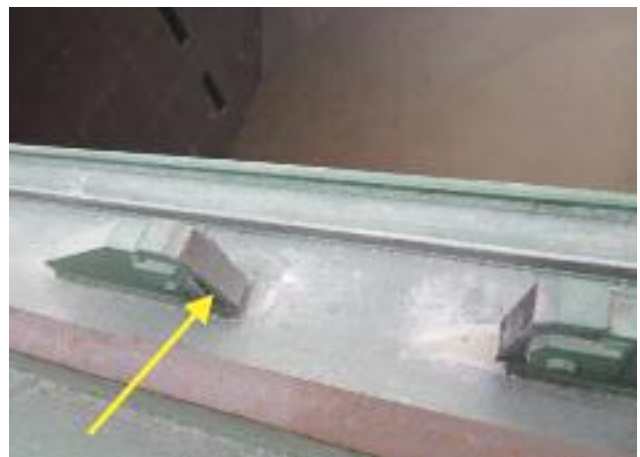

Replaceable locator pads

Stoppers

While a vessel is at sea, panels are exposed to a number of powerful forces, including loads and accelerations, as well as waves from the ocean, which will try to dislocate them from their correct sealing positions. With this in mind, it is

clear that failing to control hatch cover movements would lead to excessive loads acting on component parts of the hatch covers with accelerated wear and damage as a result. This is basically the role of stoppers (restraints). Whilst some degree of movement is allowed, stopper wear needs to be controlled and closely monitored, and it is recommended to consult the manual to obtain more information on allowable wear limits.



Excessive clearance in way of stoppers

Draining system

The drain system is the last safety barrier to water entry through the sealing system in a weathertight hatch cover system. If water enters the hatches it will be collected in the drain channel and expelled via the drain pipe. Regular inspections and maintenance of the drain channels and pipes needs to be conducted to ensure they continue to be effective.



Corrosion wasted drainpipe

Also, in heavy weather, with waves crashing over the deck and hatches, there is a risk that water will be pushed into the drain pipe and infiltrate the hold, causing wetting damage to the cargo. To prevent this from happening, drain valves should be equipped with a non-return system that needs to be checked and maintained.



Drain valve with ball inside acting as non-return system

Drain channel capacity should be carefully considered in the designing stage and damages to coaming and cross joint drain channels should be repaired.

Proper maintenance should include regular cleaning of the drain channels (as well as drain holes, drain pipes and drain valves), especially after completion of cargo operations when spilled cargo may have accumulated in the drain channels and drain pipes.



Presence of rust and debris will eventually lead to the clogging of the drain hole/drain pipe

In order to prevent drain pipes and valves from becoming clogged up by cargo debris during loading or discharge, some crews put a wooden bung in the drain hole in the coaming. This is fine as long as the plug is removed when cargo operations are completed, and before going to sea.

Finally, in order to keep extinguishing gas (CO₂) in the hold and/or prevent outside air from entering in case of a cargo hold fire, drain valves should be fitted with so-called "fire caps", which allow the drains to be closed off. Also, in case of fumigation, these caps should be fitted in order to seal off the cargo compartments.



Drain valve (yellow) with threaded fire cap firmly connected by a lanyard

Securing mechanism

Another requirement under the ICLL is that the hatch cover panels should remain in place during the voyage to prevent the holds being left open at sea, which is unacceptable, both from a safety and a cargo point of view.

The combination of multiple tasks needing to be performed in a limited time frame, has resulted in the development of a wide variety of security systems, ranging from manual systems (the normal, manually engaged, quick acting cleats used on smaller types of vessels), and hold down devices generally fitted on ships equipped with lift away type hatch covers (mainly container vessels) to automated types (auto cleating systems, hydraulic operated systems).



Corrosion and diminution of a quick acting cleat crutch and thinned down snugs

Whatever cleating system is used, it is of paramount importance that the system is structurally sound and strong. Not only the cleat itself, but also the other component parts to which cleats are welded or acting on should be fit for duty (coaming table, crutches, snugs/panel side plating). In this context, the wear component should not be overlooked. Corrosion, maintenance and sandblasting will, during the in-service life of the ship, have an effect on the cross-sectional steel thickness of the cleating arrangements, and affect the strength and holding power of the securing system.

The primary function of the cleats is to hold the panels down when the ship is at sea. However, as there will be relative movement between the panels and coaming, cleats should also cater for some movement. In many cases where ships fail an ultrasonic or hose test, the crew is seen to tighten up the cleats with spanners, cheater bars, etc. However, it is important to know and understand that cleats should never be overtightened to obtain a tighter seal. Excessive tightening makes the system too rigid and eventually results in the cleats becoming damaged. In view of the steel to steel contact between panels and coaming, it would be impossible to compress the rubber packing further once steel to steel contact has been achieved.



Overtightening of securing arrangements and crew member overtightening cleat with a spanner and cheater bar (top) until the rubber washer is reduced to pancake size (bottom)

After completion of the securing operations, it is worthwhile making a final check to ensure that the cleats are all in place and correctly positioned. Crooked cleats or cleats that are not properly fitted or engaged may be an indication of improper closing or misalignment of the panels, which should be investigated and corrected before commencement of the voyage since improperly fitted cleats will affect the holding power of the cleating system.



“Banana” shaped cross wedge



Crooked quick acting cleat (improper vertical alignment)

Compression bars

In order to achieve a tight seal, packing rubbers need to be compressed up to their design compression and as such they need to act against a compression surface. As compression bars are the mating part for the packing rubbers, their sealing surface should be smooth as a rough surface would cause rapid deterioration of the rubber surface. Whilst on older ships the standard was to have a mild steel compression bar, more modern designs are made of stainless steel.

A variety on the traditional compression bars are the flat steel mating surfaces which are used in combination with “sliding” type seals. In many cases the steel coaming plating can act as the mating surface for sliding type seals, however, it is best to weld a stainless steel strip on the coaming table as the smooth surface will contribute to the longevity of the seal during its in-service life.



Stainless steel mating surface for sliding type packing rubber on coaming

The packing rubber is not really sliding over the compression bar, but acting on the compression bar surface with a huge force (up to 9000N/m for an ordinary 90 x 50mm seal). As such, the compression bars, especially the ordinary/raised type of compression bar, need to be strong as well.

Taking into consideration the compression force that acts on the rubber packing, sharp edges can easily cause damage to the packing rubber. This is the reason why the sealing surface of the compression bars should be round shaped and not square. Replacing damaged sections of compression bars with ordinary steel flat bars (often seen in cases of stevedore damage) should be avoided.



Round shaped (top) and square shaped (bottom) compression bars

In order to ensure that the packing rubber interacts properly with the compression bar or sealing surface, contact has to be made in the correct position, and therefore, compression bars or sealing surfaces need to be properly aligned.

Whilst some limited tolerances are allowed with regards to straightness (these are generally stipulated in the maker's manual), waviness (either + or -) will lead to over or under compression of the seal, both of which should be avoided). Taking into consideration that design compression is a matter of millimetres (generally in the range of 10-12mm), even slight unevenness or waviness by a few millimetres represents a significant percentage of lack of compression or overcompression.



Compression bar waviness will result in loss of compression



Operating mechanisms

Depending on the hatch cover design, different types of opening/closing mechanisms are available. Apart from the lift away type hatch covers, which consist of pontoons that rely on shore gear to be lifted on and off, all other systems are operated with the ship's own equipment or have their own operating system. However, in many cases, and in view of the weight involved, hydraulic systems are the most appropriate system to drive the hatch cover opening/closing system, and most of these hydraulic systems incorporate cylinders, control valves, motors and pump units, which should be properly maintained. The use of hydraulics (which often operate at high pressures of up to 250 bar) in combination with heavy and moving objects presents a safety hazard for

operators and crew in the vicinity of the hatch covers. Therefore, both operators and assisting crew should be well informed and familiar with the safe operation of the system. Hydraulic systems should also be inspected for leakages, which could entail pollution and present a slip and fall hazard.



Temporary repair (rubber patch and jubilee clip) and shipboard made systems to contain hydraulic oil leakage from hydraulic piping and cylinders

The opening and closing of well maintained hatch covers should be silent and smooth. Any abnormal noise and/or vibrations during operation, wobbling wheels, creaking sound from hinges, or opening/closing times that are not in line with the manual are indications that a more detailed inspection is necessary.



Improperly maintained or wrongly operated hatch covers can result in serious damages or accidents

Hatch panels

When thinking about weathertightness, packing rubbers are often seen as the most important item. Whilst packing rubbers do compensate for the relative movements between panels and coaming, and are of paramount importance in maintaining a tight seal whilst on passage, the importance of the hatch panels should not be overlooked as it is still the steel top

plate of the hatch panels that covers up the hatch opening. Any cracks or holes in the top plating will invariably lead to water directly leaking into the hold without the possibility of it being drained off.

Another point that is often overlooked, is to check and ensure that the hatch plating and supporting structure is still sound and strong. Properly painted hatch top plating may contribute to the cosmetic appearance of the hatch covers (and is sometimes mistaken as proof that panels are in good condition), but it is the panel structure and scantlings that give the panels their strength and allow them to withstand the rigours of an ocean voyage and the accompanying sea loads.

Both advanced corrosion and stress fractures (caused by improper maintenance, improper panel adjustment, bearing pad wear, overloading, heavy weather damage, etc) will affect the structural integrity of the panels. Therefore, the structural condition of the panels should be carefully monitored.



Cracks and corrosion will affect the panel's structural integrity

Sometimes panel damage like cracks or holes are repaired with doublers. Whilst doublers might, under certain circumstances, be acceptable as a temporary repair, they are never to be considered as a substitute to a proper insert repair. Doublers will actually cover up damage and prevent water ingress, but they will never restore the original strength or stop the corrosion process. Furthermore, welding work on hatch covers needs to be carried out by trained and qualified personnel as excessive heat during welding might cause distortion of the panel structure, which is very difficult to correct.

An important issue, related to the structural integrity of the panels, is panel stiffness. It has already been explained that panel strength is important to allow loading of cargo on the panels, and to withstand weather loads. However, panel stiffness is also required to allow the panels to be opened and closed properly. Panels that lack stiffness might become deformed or distorted during the act of opening or closing, which could lead to accidents. Taking into consideration that hatch panels are required to be stiff and strong, whilst the ship itself is more flexible, explains the difficulties that have to

be overcome and the compromises made to make hatch covers weathertight.



Multiple doubler plates on the hatch top plating

Hatch cover maintenance

To ensure that hatch cover related parts and equipment are in good condition, on board inspections and maintenance are very important. However, both claims analysis and third party inspections, as well as condition surveys and claim investigations, indicate that in many cases, hatch cover maintenance is not considered to be a priority, and when maintenance is carried out, it is often not done in line with the manufacturers' guidelines and good industry practice.

Good maintenance starts with good inspections, during which items that need attention are identified. This requires proper planning (consider including it in the ship's Planned Maintenance System), developing of ship/hatch specific checklists, and educating shipboard staff in inspecting and maintaining hatch covers. Inspections should be carried out against the manual specifications, and not against the crew's or superintendent's own criteria or opinions. If inspections are carried out in a systematic way, at frequent intervals and are well documented, possible problems will be identified at an early stage, which generally allows for easier, cheaper and better repairs.

In many cases, damaged rubber packing is considered to be the chief reason for water ingress. However, what is generally overlooked is that packing rubber damage is generally a symptom rather than the root cause. A careful inspection of the packing rubber (for damage, overcompression or lack of compression, off-centre imprints) at regular intervals can give a good idea of the root cause or upcoming (more serious) problems like bearing pad wastage, excessive hinge clearance and compression bar damage.

When it appears to be impossible to have hatch covers inspected and tested by the shipboard staff, it should be considered to include this in the task of the superintendents or alternatively, appoint an external company to carry out inspections and tests at regular intervals.

Very often, necessary maintenance and repairs are only carried out after a ship has entered the loading port and fails

a hatch cover tightness test (which is generally carried out before loading water sensitive cargo). Short rubber packing inserts, applying backing strip on the packing rubber's sealing surface, use of silicon etc are frequently seen and considered as evidence of poor repairs.



Backing strips (here nailed into the original packing rubber) and short insert repairs are frequently seen as evidence of improper repairs

Commonly, and often as a last resort, abundant quantities of Vaseline or grease are applied to the packing rubbers and/or compression bars in order to pass the tightness test and satisfy (actually mislead) the attending surveyor, so that the order to begin loading can be given without any further delay. This entails a big risk as hatch covers treated and prepared in such a way might pass a test in port, but will allow water entry when at sea. It is in such cases that it is frequently seen that, although the ship passed a hatch test whilst in port, the cargo is delivered in the discharge port with wetting damage.

Whenever a substantial claim is filed against the ship, surveyors will be instructed to attend on board and carry out an investigation into the cause of the damage, which then generally reveals that in the load port, quick or improper temporary repairs were carried out, which were not sufficient to withstand the rigours of an ocean voyage. Moreover, by doing these types of improper or quick repairs, another important issue is overlooked, namely that of due diligence.

Under the due diligence principle, owners are required to carry out a reasonable inspection to ensure that the hatch covers are in good condition. If a defect is found during this inspection, then repairs should be carried out in line with good industry practice in order to restore the condition of the hatch covers.

Emphasis should be placed on the fact that a "reasonable" inspection should be carried out, i.e. a good and detailed inspection by a knowledgeable person / crew member, to confirm that all is in order. The principle of "reasonable" might change with time, e.g. 20 years ago, it would not have been reasonable to expect a shipowner to carry out an ultrasonic tightness test. However, the fact that the equipment and approved operators are more widely available nowadays would no longer make the requirement for ultrasonic testing to be unreasonable and especially when carrying water sensitive cargoes, having such a test carried out (preferably at regular intervals) and being able to document this in a proper way would demonstrate that the shipowner is aware of the importance of hatch covers and has exercised due diligence.

Another important maintenance and inspection related issue is that hatch covers are type approved equipment. Therefore, repairs involving modifications and changes made to the existing design can only be made with the approval of the respective class or flag state. Experience shows that on board repairs to coamings, brackets, panels and supporting structures are not always properly and promptly reported to the classification society or flag state. Apart from the fact that it is a class requirement to be informed of any repairs to structural items carried out on board, the involvement of class is also recommended in order to obtain the correct repair information in line with class rules. Quite often, repairs are made on board with the wrong materials, incompatible steel grades, incorrect spare parts, and this might actually give rise to more serious problems (a well-known problem here is bearing pad repairs with incompatible steel qualities between the stool and landing pads, with the development of cracks in panels and coamings as a result).



Crack progressing from the landing pad into the coaming

Finally, a good maintenance strategy also includes proper record keeping. Maintenance related documents, such as test reports, work orders, spare part orders, work schedules, hatch manual and drawings, on board checklists and inspection reports, etc. should be properly kept and filed. In case a claim for wetting damage should be filed against the ship, a well prepared maintenance file will be of great value in defending the owner's interest and proving that due diligence was exercised.

From a repair point of view, it is tempting to order cheap spares, cut costs, select the cheapest repair shop, etc. However, it should not be forgotten that, in shipping, money and profit is made by trading cargo (or transporting passengers) and well maintained hatch covers can make the difference between a profitable or loss making voyage. Claims resulting from wetting damage due to leaking hatch covers still rank high on the overall loss figures on dry cargo ships, and can weigh heavily on the owner's operational budget and profit.

Training issues

Taking into consideration that a hatch cover is a heavy, moving and high-pressure operated piece of equipment that requires regular inspection and maintenance, the ship's crew

and shore based technical staff should be familiar with the ship's hatch covers. It is therefore recommended that both general and hatch type specific training is given to those involved with hatch cover operation and maintenance.

From a hatch cover training point of view, three different types of training can be considered.

Occupational safety training

Statistics show that accidents as a result of improper hatch cover operation still occur. Unsafe practices, especially in conjunction with a lack of knowledge about the correct operation of hatch covers are a recipe for accidents and injury.



Bad and dangerous practices (sitting/walking on coaming, putting hand on trackway). Crew should be familiarised with hatch covers, their operation and safety issues

This is also recognised by the CSWP (2015 edition) where Ch. 16 addresses a wide variety of hatch cover related issues in Ch. 16.2.8 where it is stated that *"All personnel involved with the handling and/or operation of hatch covers should be properly instructed in their handling and operation. All stages of opening or closing hatches should be supervised by a responsible person"*. In practice, however, it is often seen that no proper familiarisation programme that covers hatch cover work is available on board.

In view of the different types of hatch covers (and operating conditions) involved, a one size fits all hatch cover training is not applicable. It is therefore recommended that the company uses the maker's manuals for drafting guidelines about correct hatch cover operation. Also, and if deemed necessary under specific circumstances, making a risk assessment should be considered.

Operational training

Apart from the correct operation of the hatch covers from a safety point of view, the conditions under which hatch covers can (or cannot) be safely operated should also be known and understood.

Depending on the type of hatch cover system installed on board (stacking and lift away pontoons, hydraulic operated/ wheeled systems, side rolling) operational limitations that pertain to specific ship conditions such as trim, heel, transversal and longitudinal coaming deflection will be found in the manuals of reputable manufacturers. Failure to observe these limitations whilst working out the loading/discharge plans as well as during the act of loading/discharging (uneven distribution of cargo, ballasting operations and effects of squat on river berths) might cause hatch covers to derail or result in hatch covers not being opened/closed in time. The OOW/cargo officer should be vigilant and monitor such operational limitations closely.

During the design stage, owners should be critical and try to provide manufacturers with a maximum of operational and trading information which, in their opinion, might have an influence on safe and efficient hatch cover operation (such as loaded draft, whether the vessel will be trading high density cargo or light cargoes), so that possible difficulties or problems related to hatch cover operation can be identified and tackled in the design stage. Calling in the advice of external experts in identifying specific trade/hatch type related details might help manufacturers with designing hatch cover systems.

A typical example of operational conditions is listed below:

Maximum operating conditions

- Heel $\pm 3^\circ$
- Bow Trim 0.25°
- Aft Trim 1.0°

Maximum coaming deflections on weather deck level:

Transversally

- Inwards 2 x 25mm
- Outwards 2 x 15mm

Longitudinally

- Warping over the ship's breadth 40mm
- Hogging/sagging 0.6mm/m

Inspection training

Training for inspecting hatch covers in a proper way should be considered as well.

Whilst it is beyond the ship officer's duties to examine hatch covers in the same way as experts or servicing personnel, providing the ship's staff with some useful information on the role of key parts, such as what to look for, how to make a proper inspection prior to going to sea (and making corresponding entries in the logbook as ultimate proof of due diligence) is not a big effort, and would greatly contribute to ship and cargo safety and reduce claims.

For superintendents, port captains and surveyors, a more enhanced training should be considered. Such training should not only deal with the obvious mishaps, but should provide a more profound understanding of hatch cover problems, inspections and planning for drydock, repairs, discussing repairs with shipyards, etc. Advanced courses are organised by the IMCS Training Academy (see "hatch cover level 2" training course and workshop on

www.imcs-training.eu). Also, a better understanding of hatch covers and their operation will allow for proper root cause investigation and contribute to more professional and efficient repairs.

Ultrasonic tightness testing

From the ICLL (Reg. 16.4 – “Means for Securing Weathertightness”) we note that: *“The arrangements shall ensure that the tightness can be maintained in any sea conditions, and for this purpose tests for tightness shall be required at the initial survey, and may be required at periodical surveys and at annual inspections or at more frequent intervals”.*

The above is a statutory requirement that is aimed at safeguarding life and property at sea.

However, weathertightness of hatch covers is also important for cargo interests and whilst testing for statutory and classification purposes is generally done at periodical and annual inspections, cargo interests very often include passing of a tightness hatch test as a condition for loading in the charter party.

Different testing methods exist such as light infiltration, chalk/grease test (for normal or sliding type rubbers respectively), as well as smoke tests and pressure decay, but hose testing and ultrasonic tightness tests are the most commonly used and appropriate tests for checking the weathertight integrity of hatch covers.

However, it is wrong to assume that, when a hose or ultrasonic tightness test is passed, the vessel's hatch covers are weathertight. Both testing methods give the operator or inspector an idea of the tightness condition of a sealing system, but, when taking into account ICLL criteria, having a good sealing system alone is not sufficient to conclude that the hatch covers are weathertight. This can only be concluded after a visual inspection has been carried out to confirm that all parts that contribute to achieving and maintaining a weathertight seal when the ship is at sea are in good condition.

Hose tests

When carrying out hose tests for class and statutory purposes, it is necessary to check compliance with the ICLL criteria, which require that, in any sea condition, water will not enter the hold and that, at any stage of the voyage, the load line mark will not be exceeded.

This is the reason why class surveyors will carry out a test with two persons, i.e. one surveyor on deck in order to ensure that the test is carried out correctly, and another surveyor who is in the hold to check that no water enters the hold. When considering the three safety barriers of a weathertight hatch cover system, we know that when water enters the hold during the hose test in port, there is a problem with the sealing arrangement (lack of contact that allows water to pass) and that the water ingress is so much that it can no longer be contained by the drain channel, which is the last safety barrier to water entry in the hold. This indicates a

significant problem (leakage) that will not allow to issue or revalidate the loadline certificate and requires repairs.

Whilst the drain channel will allow the collection and evacuation of water that passes through the sealing arrangements, in extreme heavy weather conditions (under normal conditions seals should not leak), it will be clear that when the vessel is rolling and pitching in a seaway, part of the water that accumulates in the drain channel might spill over the drain channel rim. Typically, this would happen when the packing rubber is no longer in contact with the compression bar, which will be the case when relative movements between the hatch and coaming (in extreme heavy weather) are more than the design compression of the packing rubber. In such a situation, and for rather short periods there would be a gap between the compression bar and packing rubber (as there would be no contact or compression any more) and eventually, water will pass and accumulate in the drain from where it is evacuated out on deck. Also minor damages to the sealing arrangements could cause similar problems. The amount of water that would enter the hold in this way (i.e. by spillage over the drain channel rim) is such that it will not put the safety of the ship and crew at risk, but might be sufficient to generate a cargo claim.

In situations where a ship encounters extreme heavy weather, and arrives with wet damaged cargo in the port of destination, and on condition that an investigation reveals that the hatch covers are well maintained, it will be accepted that the water ingress could only have been caused by extreme deflections, which were beyond the design compression and compensating capacity of the packing rubber. This would then have caused water to accumulate in, and be spilled over the drain channel, and as such, be responsible for causing the wetting damage to the cargo in question. In such cases, the wetting damage would be considered to be the result of an “Act of God” or “Force Majeure”, and any claims for cargo damage would be compensated by the cargo underwriters.

However, and when water enters under normal weather conditions that are likely to be expected when at sea (and which do not create extreme deflections), and when an investigation reveals that hatch covers are not well maintained, the damage sustained by the cargo will not be considered as being the result of heavy weather, but rather as the result of failing to exercise due diligence. This would leave the owners with little evidence to defend the claim in a successful manner.

Whilst physical damages to a sealing system are rather easy to detect during a visual inspection (cuts/missing lengths of packing rubber, gouged compression bars, etc) lack of compression in the sealing system is more difficult to observe and may not be detected with hose tests. As long as there is a physical contact between the packing rubber and the compression bar, the physical barrier that is created will prevent water passing through. However, areas with light contact may, even with relatively small movements, open up on passage and allow water to enter and damage the cargo.

Another issue to keep in mind is that the jet of water, generated by a fire hose that is equipped with a nozzle, may actually prevent the testing water to reach the rubber/compression bar interface through the cross joints. This is

because the space between the top plating of adjacent hatch panels is very small and will cause the jet of water to break apart on top of the panels instead of entering the interpanel void space. In such a case, the absence of water in the hold would not be an indication that the sealing arrangements are in order, but merely the result of lack of water and hydrostatic pressure acting on the seal.



Strong jet of water being applied to the cross joint

An improved testing method when carrying out hose tests with a view to assessing the integrity of a weathertight system (especially when delicate cargoes are to be loaded) would be to close the panel's side guttering and fill up the cross joint interpanel void spaces with water (with a fire hose without a nozzle, without applying a high pressure jet).



Filling up of interpanel void space with water from a fire hose without a nozzle

This will allow hydrostatic pressure to build up on top of the packing rubber/compression bar interface, and in case of leakage, water that passes through a leaky area would be collected in the drain channel and evacuated out on deck through the drain valve. (Note: Perimeter joints would still require a water jet for testing). Therefore, water that is seen leaking out of the drain valve during a hose test is an indication of problems with the packing rubber/compression bar interface. As a lot of water is generated during hose tests, it may not always be easy to see if water is leaking out of the drain, and therefore, it is recommended to put a plastic bag at the discharge end of the drain valve. This bag will, in case of leakage, fill up with water and provide evidence that there is a problem with the hatch cover's sealing arrangements.

When there is lack of compression in the sealing arrangement, the seal in question will open up prematurely and allow water entry. This will not only be in extreme heavy weather conditions due to extreme coaming and hull deflection but also during more clement weather conditions, which should not happen on well maintained hatch covers. As normal heavy weather conditions, say force 7-8, are encountered frequently at sea, the risk exposure for wetting damage to cargo is higher when the hatch cover packing rubber compression force and compensating capacity is impaired which increases the claim potential significantly.

In view of the above, hose tests may not be the ideal testing method to ensure that the hatch cover's sealing system is fit for service, especially when considering cargo safety, as they do not provide information on the packing rubber compression. When it comes to checking sealing systems for compression, ultrasound testing may provide additional information and evidence.

Ultrasonic tests

Explaining the ultrasound tightness testing method is a bit more difficult as using ultrasound detection equipment is more complicated than aiming a jet of water to a panel joint. It is beyond the scope of this brochure to provide a scientific contribution on ultrasound technology, but the basics of ultrasound will, in simple terms, be explained below.

The ultrasound testing principle is quite simple. Ultrasound equipment for hatch cover tightness testing requires a transmitter and a receiver unit. The transmitter emits ultrasound and is placed in the ship's hold.



Transmitter being placed in the ship's hold

Once the hatch covers are closed, the operator scans the sealing areas of the closed hatch covers (cross joints and perimeter rubber/compression bar interface) with the receiver unit and will detect ultrasound signals that are passing through the seal with pin point accuracy, which allows for quick and easy detection of leaky areas.

Ultrasound testing is based on the characteristics of a piezo electrical crystal, which vibrates when subject to an electrical current and which, when squeezed, discharges an electrical current, which can easily be measured.



Checking tightness via the cross and perimeter joints

As such, we are able to measure the strength of an ultrasound signal, a signal that would not be heard by the human ear (if it was not heterodyned). Following the above logic, a small leak will only allow a small amount of ultrasound to escape and hit the receiver's sensor, which will result in a small electrical current being discharged, resulting in a low measurement, which is an indication of a small leak. In case of a big leak, a "cloud" or "beam" of ultrasound will hit the receiver's sensor and cause a significant electrical discharge, resulting in a high measurement that indicates a big leak.

Within the scope of ultrasonic testing, the word "leakage" may not be completely correct. It would be more appropriate to use the words "lack of compression" as this is what is being detected in a spot or area where the packing rubber lacks sufficient compression force to provide a tight seal. Only when there is a transition from lack of compression to lack of contact, will water start to infiltrate and cause a real (water) leak.

In order to obtain an idea of the importance of a leak, a reference value is useful. This reference value is found in the form of an "open hatch value" (OHV), which is the ultrasound signal that is measured through an open hatch, i.e. a 'big hole'. The value measured through the open hatch will be quite significant, and is, in fact, the highest value one can find for a particular hold (the measurements recorded during the test will and can normally not be more than the OHV). The fail-pass criteria for an ultrasonic test has been set at 10% of the OHV and not 0%, which provides an acceptable tolerance for a certain degree of wear on the sealing system.

The biggest advantage of ultrasound testing is that the test results give an indication of not only the contact with the packing rubber, but also the compression of it. If compression is good, then we know that the packing rubber has sufficient compression force, which means that the rubber packing will be able to compensate for relative movements and, as such, provide a tight seal. The fact that we can find out whether the rubber will perform well at sea whilst the ship is still in port provides extra safety. Moreover, in hatch cover tightness, compression is the governing factor and not contact.

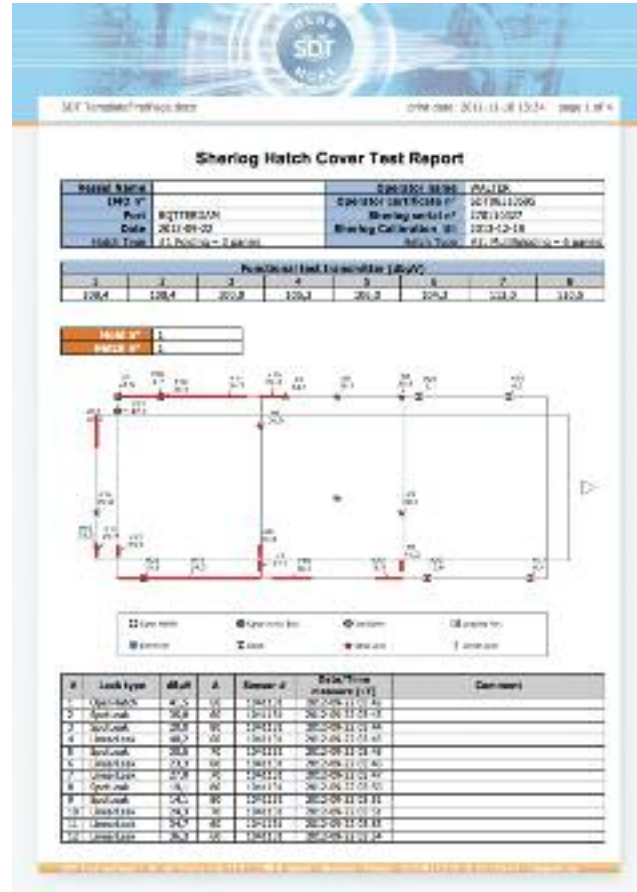

Typical example of a hatch cover test report

Other advantages offered by ultrasound tightness testing are:

- One man operation (observe safety!)
- No pollution risk
- Not limited by temperature/weather
- Possible during day/night
- Pinpoint accuracy
- Quick and easy to use
- Holds can be loaded/emptied
- A clear pass/fail criteria can be set resulting in enhanced safety
- Professional test report can be generated in a few seconds
- The test is (or should preferably be) carried out by a qualified operator

However, this is not completely correct as it is impossible to say that hatch covers are weathertight on the basis of an ultrasonic test alone. This is because, with ultrasound testing, only the sealing arrangement is tested. Whilst this is indeed an extremely important part of the hatch cover arrangement, the sealing arrangement alone does not make a hatch cover weathertight.

Weathertightness also depends on the other key parts that help the hatch covers and sealing system to be weathertight and remain weathertight (and safely secured) during the voyage. Therefore, the condition of these key parts also needs to be assessed, and this can only be done with a visual inspection. This is also clearly explained in the DNV 403 tightness testing procedure, which states that, in case measurements taken during an ultrasound test are <10% OHV, the hatch covers can be considered to be weathertight “subject to a visual inspection”.

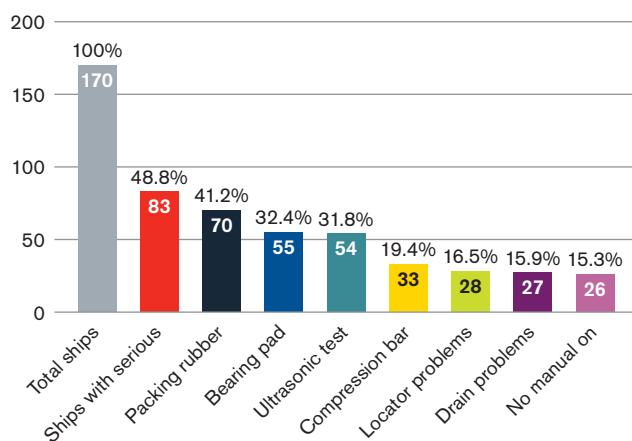

Main hatch cover problems in numbers and %

Almost 50% of the 170 ships inspected over a three month period had serious hatch cover related problems that would affect weathertightness

So in order to advise on whether or not a hatch cover is weathertight, both tightness test results and visual inspection details should be considered.

Of course, it is a fact that carrying out a visual inspection of the hatch covers will take more time, as will the drafting of a test and inspection report with photographs. Both time pressure and costs result in many principals only asking for an ultrasound inspection, as they are convinced that this will be sufficient, which is actually not the case.

Whilst operating ultrasonic test equipment is not difficult, it requires some skill and experience to use the equipment in the correct way. Operators should also learn how to evaluate the measurements obtained during a test on board a ship.

Another practical problem is that there are many surveyors and inspectors who have an ultrasound testing kit, but there are not many operators who are able to carry out a good visual inspection as well. Therefore, it may not always be easy to obtain the necessary and correct information to evaluate whether the ship's hatch covers are indeed weathertight or not.

The fact that the importance of a visual inspection should not be underestimated is also made clear by the IACS UR Z17 procedures for service suppliers, which requires operators using ultrasound equipment for tightness testing of hatch covers to be familiar with hatch designs, hatch cover operation, maintenance and repairs, etc.

Another reason why operators of ultrasound equipment should have a good understanding of hatch covers is that, prior to the test being carried out, they should be able to confirm that the hatch covers are ready for testing. Evidence such as crooked/misaligned cleats, improper steel to steel contact, misaligned or mismatching panels, are indicators that the panels are not properly closed and battened down, which might result in lack of compression and affect the test results.

Operators should also be aware of the effects of grease or Vaseline on the packing rubbers, as well as of the effect of overcompression on test results, false echoes, etc.

Once the test is completed, the biggest challenge is to evaluate the test results and find out if the hatch covers are fit for duty. In this context, readers should be aware of the fact that ultrasonic tests are carried out in order to provide information on the possible risk of water ingress (and damage to the ship and cargo). It is therefore important to understand the meaning of the readings obtained during the test and link this data to the possibility of water ingress. The most dangerous conclusion that one can make is to say that, if during an ultrasonic test no measurements in excess of 10% OHV are found, the hatch covers are weathertight and that there is, therefore, no risk of water ingress and cargo damage. As stated earlier, hatch covers can only be considered weathertight when they pass an ultrasonic test and when a visual inspection indicates that all the parts that contribute to achieving and maintaining weathertightness are in good condition.

Another example is that many decision makers will be concerned when they receive a report that indicates a number of red dots/stars (spot leaks) that are in a range of 50% or more of the OHV. On the other hand, they will feel quite relaxed to see a measurement that is slightly above the fail-pass criteria value over a longer length in a cross joint. What is important and necessary in order to make the correct conclusions is to understand that ultrasound measurements reflect a certain degree of compression (or lack thereof) and of course, the higher the measurement, the more compression has been lost. The real question that needs to be answered is: How much water will infiltrate the hold as a result of the leaky spot that is found? In the case of spot leaks with a high value, water can indeed infiltrate, but the overall amount that will infiltrate is unlikely to be that much that it cannot be safely evacuated by the drain system. However, in the case of the leaky cross joint, the main issue is that even a reading that is slightly above the fail/pass criteria indicates that there is lack of compression in the sealing arrangement over a longer length. This is generally a more dangerous situation as the readings in this case indicate that there is loss of compression over a longer length and this means that the seal will open up prematurely, i.e. during more clement weather conditions where distortions between the panels and the panel/coaming are not excessive. In the case of a cross joint opening up over a longer length, the amount of water that can infiltrate will be significant, and this will normally result in a more significant amount of water being spilled over the drain channel rim.

The above example makes it clear that a few spot leaks with high values might not always present a big risk or result in a significant claim, and therefore, it may well be that, from an ingress and claim potential point of view there is no need to overreact or panic. After all, as long as the water can reasonably safely be evacuated by the drain channel, there is no risk of being non-compliant with the ICLL, and the overall risk exposure for cargo damage will be remote.

Hatch covers and due diligence

Most of the claims that are filed on the grounds of hatch cover leakage are commercial related, rather than statutory related. In cases where cargo has sustained wetting damage, it is often assumed that the shipowners failed to carry out due diligence. In the context of hatch covers, and as explained earlier, due diligence requires the master/shipowner to carry out a normal and reasonable inspection to ensure that the hatch covers are in good condition. However, when defects are noted during a test or visual inspection, it is expected that the necessary steps are taken to correct the situation. It is important that corrective actions are made in line with good industry standards and the manufacturer's guidelines.

Very often, when being faced with unsatisfactory test results, marine sealing tape, expansion foam, etc. are used to mask the leaky spot, which is not in line with the due diligence principle. The use of extra sealants allows claimants to assume that the master/shipowner was aware of the tightness problem and decided not to repair it in the proper way, and opted for the cheapest and quickest solution that would allow him to start the voyage and meet the commercial deadlines. By doing so, the master/shipowner fails in his duty to provide a seaworthy and cargoworthy ship and also fails in his duty to look after the safety of the ship, crew and cargo by not complying with the due diligence requirements.

It is, however, a fact that many charterers or shippers are asking masters to apply sealing tape after loading, and by doing so they put the master in a difficult position. On the one hand, masters have the duty to cooperate with charterers and comply with reasonable requests that do not affect the ship's safety, but on the other hand, masters are (or should be) aware of the fact that applying marine sealing tape might put them in a difficult position in case the cargo sustains wetting damage during the voyage. In such cases, masters and owners should ensure that they can prove that, before applying the sealing tape, the hatch covers were weathertight, i.e. passed an ultrasonic (or hose) test, and that a visual inspection confirmed that all hatch cover parts are in a well-maintained and good condition. It would be wise to call in the assistance of a surveyor to carry out the hatch cover test and inspection, as a third party confirmation that all is in order would provide good evidence. Of course, if defects are found during such an inspection, they should be addressed in a proper way. Finally, making a note in the ship's logbook stating that the hatch covers were tested and inspected, and found to be in order (and making reference to the test/inspection report), and that the sealing tape was applied at the request of the charterers or shippers would be further proof of a professional approach towards the use of sealants.

One thing that is also often overlooked when it is decided to apply marine sealing tape (various types are currently on the market), is that this sealing tape adheres strongly to the hatch panel surface (it is even recommended to heat the panel surface/tape to ensure proper adhesion, especially in cold weather). Upon completing the voyage, the tape is then removed, but generally during this removal process, paint becomes detached, leaving the panel surface unprotected and exposed to the elements, with corrosion setting in. Maintenance of the areas with coating breakdown is time consuming, especially when the sealing tape is applied on all hatch covers, and will divert attention from other (and perhaps more necessary) shipboard maintenance tasks. When owners are convinced that their hatch covers are in good condition and able to prove it, it is better to reconsider the charterers' request to apply marine sealing tape and/or to include in the C/P that no sealing tape will be applied.

Evidence to produce in case of a claim

In the unfortunate event that a claim for wetting damage is filed against the ship, even when the hatch covers are well maintained and in good condition, it is considered good practice to provide the below information and evidence of due diligence in order to help your P&I club and lawyers to defend the owner's interest.

- Work schedules
- Maintenance logs and test reports
- Work specifications
- Accounts
- Standing instructions
- Reports and correspondence
- Logbook entries
- Hatch patentee manual
- Holding valid (relevant) certificates
- Evidence of planning voyage and weather reports
- Proof of operating the ship in a good seamanlike manner during the voyage (C/C, RPM...)

Of course, and when appropriate, a sea protest should be prepared as well, and a local P&I surveyor will be able to assist the ship's staff with further survey and test requirements.

Main problems found

Experience has revealed that, when testing and inspecting hatch covers, the following typical or frequently seen mistakes are identified:

Common mistakes

- Insufficient knowledge about hatch covers, not allowing for good inspections and proper, understandable reporting
- Overestimating the capability of the ship's crew for repairs (maintenance and adjustment)

- Overlooking the importance of involving class when shipboard repairs are carried out to hatch covers
- Improper or temporary repairs by crew
- Missing manuals and drawings
- No on board instructions for maintenance
- No maintenance files on board (PMS)
- Hatch covers not included in SMS
- No understanding of the due diligence principle/issues

Weather tightness mistakes

- Ignoring discard/replacement criteria (overcompression)
- Replace rubber and not fix the pads
- Install backstrip rubber everywhere
- Mix new and old rubber
- Using old rubber (from shipboard stock, ignoring shelf life)
- Use small pieces and fill in gaps
- Not (or lightly) painting rubber channel

Mechanical mistakes

- Ignore abnormal sounds/vibration during operation
- No greasing, no greasing plan
- On board repairs instead of ashore
- Ignoring safety issues (heavy and moving equipment)

Hydraulic mistakes

- Cleaning filter instead of changing it
- Improper filtering
- Close covers without pump
- Change pipes without flushing
- Valve positions during voyage
- Ignore leaks and pollution risk
- Ignore high pressure risk

CONCLUSIONS

As you will have seen above, answering the simple question “are the hatch covers weathertight” is slightly more complicated than generally believed, and cannot be confirmed by carrying out an ultrasonic test alone. It actually requires knowledgeable and professional people to carry out the test and advise principals not only about the test results, but also about the overall condition of the hatch covers, their key parts and possible exposure to risk and water ingress.



IMCS Group of Companies

The history of the IMCS Group of Companies goes back to 1990 when IMCS-Belgium was founded in Antwerp. From 1993, IMCS branch offices were set up in strategic locations throughout Europe and in the Baltic and Black Sea areas.

In 2001, under the Chairmanship of Walter Vervloesem (FNI), the “IMCS Group of Companies” was set-up with a view to strengthening ties between the different IMCS entities, streamlining survey and reporting standards, and enhancing professionalism through an in-house quality system, training programs, seminars and Group meetings.

After 2005, further expansion included representation in overseas areas such as China and Brazil and in 2016, offices in Chile and India were set-up.

The worldwide IMCS Group network presently comprises 20 offices, and our surveyors carry out 5000+ surveys per year. More than 1000 hatch cover and cargo worthiness surveys (part of which are within the scope of dedicated ship inspection programs) are carried out annually by a team of highly trained surveyors.

The recent economic downturn brought several challenges, which were turned into opportunities by recognising our principal's needs and working out tailor-made solutions, developing dedicated ship vetting platforms and setting-up the IMCS Training Academy as well as by embracing modern techniques such as 3D scanning and the use of drones.

Throughout the years, IMCS has worked hard to make quality its hallmark, and significant efforts are made every day to ensure high standards of performance and customer satisfaction.

The Author

After leaving the sea in 1988, Walter Vervloesem (FNI) redirected his career and became a marine surveyor and consultant. He joined IMCS Belgium in 1995, and became Chairman of the IMCS Group in 2001. He pioneered the use of ultrasonic tightness testing back in the late eighties and early nineties, and is the training instructor for the SDT-IMCS worldwide training program for operators using ultrasonic tightness testing equipment for testing the weathertight integrity of hatch covers. In 2011, he founded the IMCS Training Academy. Walter is the author of several major reference works published by the Nautical Institute, such as “The Ship Survey and Audit Companion” (2000), “Hatch Covers Inspections” (2004), “Mooring and Anchoring Ships” (2009) and has contributed to many books and articles for leading maritime organisations.

IMCS Belgium
Noorderlaan 79 – bus 6
2030 Antwerp, Belgium
Tel: +32 3 4582930
Mob: +32 475 46 81 63
e-mail: walter@imcs.be
web: www.imcs-group.com

UK P&I CLUB



HOMARUS Limited
Fisheries and Aquaculture Specialists

RISK FOCUS: REDUCING THE RISK OF COLLISIONS WITH FISHING VESSELS

A guide for Masters and their Bridge teams.



UK P&I CLUB
IS MANAGED
BY **THOMAS
MILLER**

Reducing the risk of collisions with fishing vessels

Close quarter situations with fishing vessels and/or their associated fishing gear remain common. This often results in loss of life, in addition to any damage to fishing gear or boats.

The range of equipment that fishermen deploy to catch fish is almost as varied as the fish themselves, but there are a number of common fishing methods that are used and these methods will be explained, together with the lights and shapes that should be exhibited, the likely position of the gear in relation to the boat and typical fishing manoeuvres to be expected.

During the Passage Planning process, it may be worth contacting the vessel's local agent or the local harbourmaster to enquire whether there are any particular fishing-related dangers to be considered when approaching a particular region or port. During calm weather, extra vigilance is required as this is the time when many small fishing vessels will go to sea.

IMPORTANT NOTE

The following descriptions and diagrams representing various types of fishing indicate what can be expected of small to medium scale fishing vessels fishing in coastal waters, (within 20 miles of land).

Small scale craft are more likely to be fishing in or around approach channels and ports and cause the most navigational problems and uncertainties. However, much larger vessels and gear also fish in the same way and in the same layout.

The upper sizes of vessels and gear used are generally not shown in the diagrams; to do so would make them almost meaningless. But mariners should be aware of these fishing practices and that fishing gear can extend a long distance from larger vessels, albeit in the same proportions as those shown in the diagrams herein.

Less focus is given to larger vessels as they should normally fish further offshore, keep a proper watch, use VHF and AIS and show proper shapes and lights and so cause fewer problems for safe navigation.



The nature of fishing

- Fishing boats get their cargo at sea so their main focus is on catching fish;
- Fishermen generally do not receive a wage, but are paid a share of the proceeds of the voyage;
- Fishing vessels often operate with minimal crew;
- Fishermen are sometimes poorly qualified;
- Fishing vessels often do not show correct lights or day shapes;
- Fishing vessels often operate in channels and harbour approaches.

Most maritime traffic involves carrying a cargo (goods or passengers) across the sea from point A to point B. This traffic is generally well regulated and is overseen by highly qualified personnel. A fishing vessel however leaves port empty and tries to find its cargo at sea, hopefully returning with a full hold. Hence the focus of a fishing vessel is not necessarily on safe navigation but on finding and catching enough fish to make a profitable voyage.

Fishermen generally do not receive a wage, but are paid a share of the profits of the voyage. Thus it is in the interests of the whole crew to catch as much fish as possible in the shortest time possible to achieve maximum profitability. This can lead, in some circumstances, to fishing becoming the primary objective and safe navigation a secondary consideration.

This share system also often leads to crew numbers being kept to an absolute minimum, in order to maximise each person's share. Consequently, unlike in the merchant service, watch arrangements, particularly on smaller vessels, are often haphazard. During periods of heavy fishing or when gear maintenance is necessary, it is often a case of "all hands on deck" and it is not uncommon for crew members to work for 24 hours or more without a break. This leads inevitably to fatigue and loss of concentration. Additionally, the crew may be involved in handling heavy and dangerous gear in poor weather and may not be fully focussed on keeping a good lookout.

On larger fishing vessels, particularly in countries where tight regulations exist and are enforced, this problem generally does not arise. Indeed in some countries larger vessels may carry a Captain who is responsible for the safe and efficient operation of the vessel and a Fishing Master (the "Patron") who is responsible for finding and catching fish.

However, on smaller fishing vessels and in regions where regulations either are poorly drafted and / or not enforced, the situation will be different. Many countries do not require any qualifications at all for a person to take a fishing boat to sea, and even where qualifications are required they are frequently fairly lax and do not require regular updating. In the case of small and / or single-handed fishing vessels, of which there are huge numbers across the globe, the focus is on catching fish and there will be no lookout and probably no fishing signals or lights and even no radar reflector.

On the high seas problems with fishing vessels are infrequent. The vessels are large enough to carry sufficient crew and are usually well regulated and maintained and there is enough sea room to manoeuvre. The closer to land, the more likely there are to be interactions between merchant vessels and fishing vessels, particularly in Traffic Separation Zones, narrow channels or straits and the approaches to harbours or anchorages. Here, small vessels may be common, and the larger merchant vessels are often restricted in their ability to manoeuvre.



Fig 1. Small fishing vessels in a crowded harbour approach, Lagos, Nigeria

How things should be

The International Regulations for Preventing Collisions at Sea (1972) ("COLREGS") specify lights or daytime signals that should be shown by fishing vessels engaged in different types of fishing, and which vessels have right of way under differing circumstances. The term "vessel engaged in fishing" means any vessel fishing with nets, lines, trawls or other fishing apparatus which restrict manoeuvrability, but does not include a vessel fishing with trolling lines or other fishing apparatus which does not restrict manoeuvrability.

In general both sailing boats and power driven vessels should give way to vessels engaged in fishing. Exceptions¹ to this rule include:

- A vessel engaged in fishing shall not impede the passage of any other vessel navigating within a narrow channel or fairway.
- For Traffic Separation Zones –
 - A vessel engaged in fishing shall not impede the passage of any vessel following a traffic lane.
 - A vessel other than a crossing vessel or a vessel joining or leaving a lane shall not normally enter a separation zone or cross a separation line except to engage in fishing within a separation zone.
- A vessel engaged in fishing when underway shall, so far as possible, keep out of the way of:
 - a vessel not under command;
 - a vessel restricted in her ability to manoeuvre.

¹ This is merely an outline and should not be considered to be an exhaustive analysis of the Collision Regulations.

Lights and signals that should be shown by vessels engaged in different types of fishing are detailed later.

How things often are

Although the COLREGS should technically apply to all vessels of all Member States, they are very often overlooked or ignored. On small vessels in some regions of the world, it is common to have an unqualified skipper and crew who know little about safe navigation. Remember, many of these fishermen are poor, ill-educated and desperate to make a living. Safety is often a secondary concern.

What you may encounter is a number of unlit or poorly lit small vessels, with no radar reflectors, no lookout, gear stretching out to an unknown distance and unknown direction and working close to or within the confines of a channel or harbour approach.



Fig 2. Small fishing canoes in Lagos Harbour, Nigeria. Note absence of lights, day shapes etc.



Fig 3. Small static gear vessel, South Korea. Note the absence of any lights or day shapes.

Fishing gear and fishing methods – general features

There are countless methods that man has devised for catching fish. Many of these are specific to inland or coastal waters and will rarely be encountered. The remainder can be divided into four broad categories:

- Mobile or towed gear
- Encircling gear
- Passive mobile gear
- Fixed or static gear

There are some gear types that cross boundaries between the above classifications. Further details of each method are given later.

Mobile or towed gear

This category includes, among others, trawls and dredges. The primary characteristic is that the gear is dragged through the water and is not attached to the sea bed. Fish are generally caught in a bag of net which is hauled aboard and emptied. For trawls, the wires or warps that attach the net to the boat may also act as a herding mechanism, concentrating the fish at the mouth of the net at which point they are engulfed. The main difference between trawling methods is the means by which the cone-shaped bag of net is held open while being dragged through the water.

Encircling gear

These methods rely on surrounding the fish either with a wall of netting which is then closed at the bottom and hauled in (purse seining) or with ropes that herd the fish across the sea bed towards the net that scoops them up (anchor seining, fly dragging).

Passive mobile gear

Here the gear is mobile but it is not towed by engine power, but drifts with the tide or wind. This category includes drift nets, surface longlines and squid jigging. These gears may extend very long distances from the boat.

Fixed or static gear

These types of gear are generally fixed to the sea bed by anchors. They rely either on bait to attract the fish to the gear (hook and line, pots and traps) or on fish becoming entangled in the mesh of the nets (gill nets or tangle nets). These gears may extend very long distances from the boat.

Mobile or towed gear

General notes

This category includes trawls of various types and dredges. Vessels using this type of gear should all show the same day shapes or lights as follows:

- By day, two cones pointing towards each other in a vertical line one above the other. Small vessels may fly an inverted basket in the rigging.
- By night, all-round green light over all-round white light, plus sidelights and sternlight when underway.
- Additionally, a vessel over 50m in length should show a masthead light above and aft of the all round green light; for vessels less than 50m this is optional.
- When fishing in close proximity to other fishing vessels the following signals should be shown:
 - When shooting the net, two white lights above each other or Flag Z by day;
 - When hauling the net, a white light over a red light, or Flag G by day;
 - If net has become snagged on an undersea obstruction, a red light over a red light or Flag P by day

The above all-round lights should be fixed lower than the main fishing lights and of lower intensity, but still visible at 1 mile.

In addition, when pair-trawling (i.e. one net towed between two boats) each vessel should shine a searchlight forward and in the direction of the partner vessel (Flag T by day).

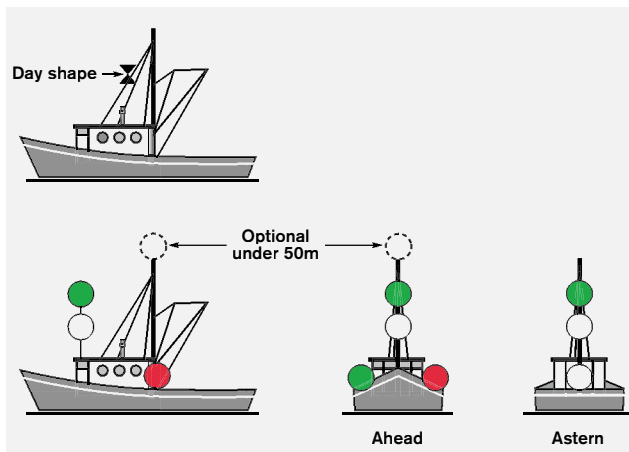

Fig 4. Day shapes and lights for trawlers

Single boat trawling or otter trawling

Brief description of fishing method.

Otter trawling is also known as dragging in some regions of the world, particularly in the US and Canada. With this method, the mouth of the net is held open by the shearing action of two essentially flat boards (otter boards or trawl doors), one either side of the net. These are angled in such a way that as they are dragged through the water they will shear away from each other and will exert an opening force on the net. The doors are attached to the vessel by wire warps (whose length is usually around 3 x the depth of the water) and to the net by wire sweeps, known as bridles. The action of the doors and the sweeps tends to create a sediment cloud which herds the fish towards the mouth of the net where they are caught.

The mouth of the net has floats along the top edge (the headrope) and a weighted line along the bottom (the footrope) which enables it to have a vertical opening. The far end of the net is tied closed; this is where the fish accumulate and is known as the "cod end".

The trawl is either dragged along the seabed to catch bottom-dwelling fish such as cod or flatfish (demersal or bottom trawling) or is used in midwater or near the surface to catch shoaling fish such as mackerel or herring (pelagic or midwater trawling). Towing speed varies according to the target species but is usually between 2 and 4 knots.

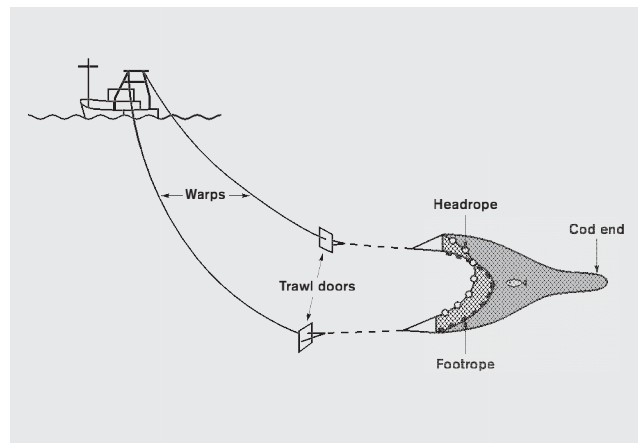

Figure 5: Otter trawling (3D view)

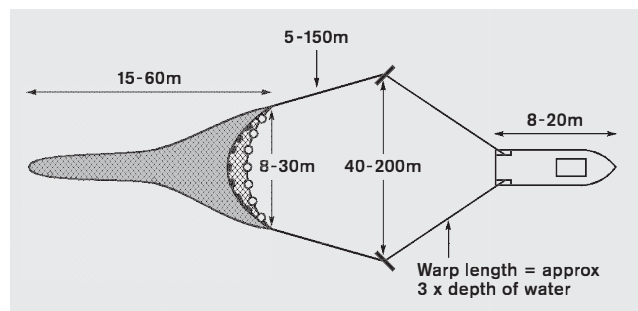

Figure 6: Otter trawling (plan view). Note: dimensions are for smaller, inshore vessels. Larger, offshore vessels can be up to >100m length and fish in waters up to >1000m deep.

Main safety issues

- Manoeuvrability is restricted during all parts of the operation;
- Vessel should display a green light over a white light;
- Gear is generally astern of the vessel;
- Safe passing distance (astern) is at least 250m and may be more for a large vessel.



Fig 7. Typical small inshore trawler showing trawl doors hanging on aft gantry and net wound onto a net drum (UK).

Deploying and retrieving the gear.

In most modern vessels the gear is both deployed and retrieved over the stern. Some older vessels may set and retrieve the net over either side of the vessel. The net is shot away first, followed by the bridles or sweeps; the trawl doors are then clipped on to the end of the bridles. Then the main warp is paid off to approximately 3 times the depth of water.

After towing for the appropriate time the warp is winched back in and the doors unhitched; the vessel maintains way during this process, usually heading into the wind. After the bridles have been retrieved, the net itself is either brought on board completely, up a stern ramp or onto a hydraulic net drum mounted at the stern, or the cod end is winched round to either aft quarter and brought aboard there and emptied. In the latter case the vessel will come to a halt with the cod end on the windward side, thus blowing the boat away from the net to avoid fouling with the propeller. After the cod end is emptied, the net is shot away again and the process is repeated until the end of the voyage.

Some trawlers employ two or even three trawl nets together, with an arrangement of weights or skids to balance the configuration. This, however, does not radically alter the basic processes above.

Except during the final stages of hauling, a trawler always has the gear deployed astern. While the vessel is towing, the gear may be any distance from 100 m to 2,000 m astern, depending on the size of the boat and the depth of water. However, the great majority of this is likely to be underwater and, even in the case of midwater trawling, it is unusual (though not impossible) for the net to be close enough to the surface to present a fouling hazard.

What is likely to be seen from the bridge of a larger vessel?

Apart from the day signals or lights as outlined above, a trawler is likely to show some or all of the following characteristics:

- A stern ramp sloping into the water up which the net can be dragged onto the deck, or;
- A hydraulic net drum or drums mounted on an aft gantry onto which the net will be wound;
- A steel structure either side at the stern onto which the trawl doors are attached;
- When towing the net, 2 warps (or possibly 3 in the case of multi rig trawls) leading diagonally down into the water astern of the vessel.
- At night it is likely that bright working lights will be showing, generally around the stern of the vessel.

What manoeuvres are the vessel likely to make.

Once towing, a trawler will generally proceed more or less in a constant direction as the weight of the trawl on the seabed makes rapid change of course impossible. Deviations to the course will be made in order to avoid known seabed obstructions, but these will be gradual. When hauling, the vessel may turn fairly quickly upwind once the trawl is near the surface and, if hauling over the aft quarter will turn so that quarter is facing into the wind.

What are likely hazards / interactions?

Fouling of the trawl warps with the hull or rudder of a merchant vessel is possible if passing too close astern of the trawler – this will cause the trawler to be towed backwards and will very likely lead to capsize, particularly if it is a small vessel. If passing too close, the wake or wash may cause severe rolling or possible capsize of a small trawler. Merchant vessels should either pass ahead of a trawler, given sufficient room, or well astern (>500m) if possible.



Fig 8. Typical small inshore trawler (India)

Pair trawling

Brief description of fishing method.

With this method, the net is towed by two boats running a parallel course, providing the horizontal spread for the net. Each partner vessel will carry its own net; these are used alternately. Without the drag caused by using trawl doors, a much larger net can be used. Depending on the size of the net, the two vessels may be as much as half a mile apart. Pair trawling may be used in midwater or on the sea bed depending on the target species. Towing speed is likely to be between 2 and 5 knots.

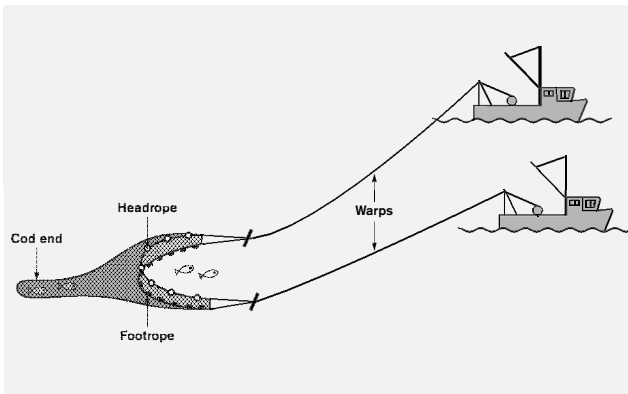

Figure 9: Pair trawling (3D view)

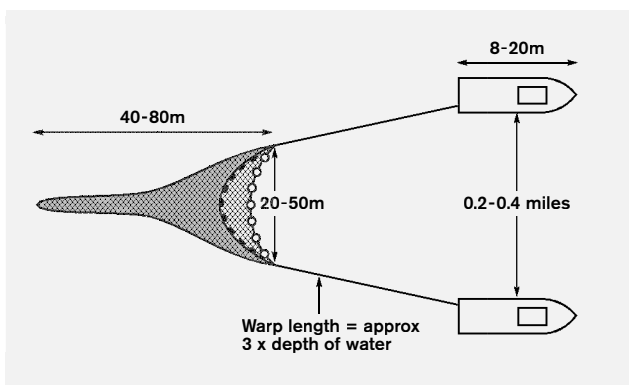

Fig 10. Pair trawling (Plan view). Note dimensions are for smaller, inshore vessels. Larger, offshore vessels can be up to >100m length and fish in waters up to 1000m deep.

Main safety issues

- Manoeuvrability is restricted during all parts of the operation;
- Vessel should display a green light over a white light;
- Gear is generally astern of the vessel;
- Safe passing distance (astern) is at least 250m and may be more for a large vessel;
- Vessels are particularly vulnerable when close together to pass the towing warp.

Deploying and retrieving the gear.

The net is deployed from one vessel until it is streaming astern, at which point a messenger wire is passed to the second vessel which then attaches one side of the net to its own warp. The two boats then steam ahead and away from each other, paying out the warps, until the required distance apart is reached; they will then run on a parallel course.

When hauling the net, the reverse of the above takes place, and the net is hauled aboard and emptied. The second vessel will then shoot its own net and so the operation continues until the end of the voyage.

What is likely to be seen from the bridge of a larger vessel?

Day and night signals are the same as for the single boat trawling except at night when each vessel will shine its searchlight forwards and towards the partner vessel. Also look for:

- A stern ramp sloping into the water up which the net can be dragged onto the deck, or;
- A hydraulic net drum mounted on an aft gantry onto which the net will be wound;
- When towing the net, a single warp from each vessel leading diagonally down into the water astern of the vessel;
- At night, each vessel should shine its searchlight diagonally forwards in the direction of the partner vessel;
- At night it is likely that very bright working lights will be showing, generally around the stern of the vessel;
- Radar should show two vessels on a parallel course between around 0.25 and 1 mile apart.

What manoeuvres are the vessels likely to make?

When shooting or hauling the net the two vessels will come very close together – this is the most dangerous part of the operation, particularly in poor weather. Otherwise the two vessels will maintain a constant distance apart, and any changes to their course will be gradual. If hauling the cod end over an aft quarter, the vessel will turn to have the wind on that side.

What are likely hazards / interactions?

Fouling of the trawl warps with the hull or rudder of a merchant vessel is possible if passing too close astern of the trawlers. Getting between the pair of vessels should be avoided, particularly during hauling and shooting operations. If passing too close, the wake or wash may cause severe rolling or possible capsize of a small trawler. Merchant vessels should either pass well ahead of pair trawlers, given sufficient room, or well astern (>500m) if possible.

Beam trawling

Brief description of fishing method.

With this method the mouth of the net is held open by a steel beam (this might be wooden in a small scale fishery) to which the bag of net is attached. The beam is held off the seabed by steel skids or shoes. The top of the net is held off the seabed by the beam, while heavy chains along the footrope ensure good ground contact. This method is used to catch fish that live on or close to the seabed. The gear is often heavy and cumbersome with the beam on a larger vessel being as much as 12 m long and the gear weighing as much as 8 tonnes. Towing speed may be as high as 7 knots.

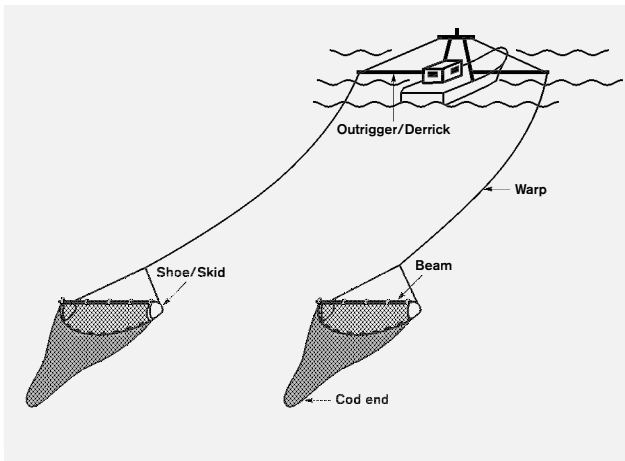

Fig 11. Beam trawling (3D view)

Most beam trawlers use two nets, with one deployed either side of the vessel usually from a derrick that can be swung outboard. Sometimes a single beam trawl is deployed over the stern of the vessel

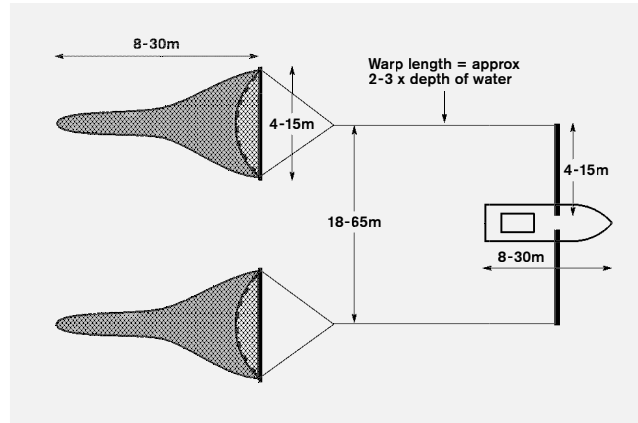

Fig 12. Beam trawling (Plan view). Note dimensions are for smaller, inshore vessels. Larger, offshore vessels can be up to >50m length and fish in waters up to 500m deep.

Main safety issues

- Manoeuvrability is restricted during all parts of the operation;
- Vessel should display a green light over a white light;
- Gear is astern of the vessel or alongside at the hauling and setting procedure;
- Safe passing distance (astern) is at least 100m and may be more for a large vessel;
- Vessel is particularly vulnerable to wash or wake when deploying or retrieving the heavy gear.



Fig 13. A beam trawler deploying both nets

Deploying and retrieving the gear.

At the beginning of fishing operations the beams are winched outboard and the net deployed whilst the vessel is steaming ahead. The gear is then lowered to the seabed and towing starts. When the gear is hauled, the beam is brought up alongside the vessel while the cod end is winched aboard, emptied and re-set. The vessel is steaming slowly ahead during this operation.

At the end of the voyage the beams and the nets are winched aboard and secured.

What is likely to be seen from the bridge of a larger vessel?

Day and night signals are the same as for the single boat trawling. Also look for:

- An outrigger or derrick on either side of the vessel which will be near horizontal when fishing.

What manoeuvres is the vessel likely to make?

The boat is likely to steam into the wind when hauling or shooting.

What are likely hazards / interactions?

Due to the heavy gear, the warps will not extend very far astern at the surface, so there is little chance of entangling. Passing too close may cause problems with wash / wake.

Dredging

Brief description of fishing method.

A dredge is usually a steel frame with a bag of netting and / or steel rings attached. The front edge usually has teeth which dig into the sediment. Dredges are mostly used for catching shellfish such as scallops, oysters, clams, mussels etc.



Fig 14. Typical shellfish dredge

Dredges are either towed singly from the stern, in pairs with one towed from each quarter, or in larger numbers, attached to a steel beam similar to a beam trawler.

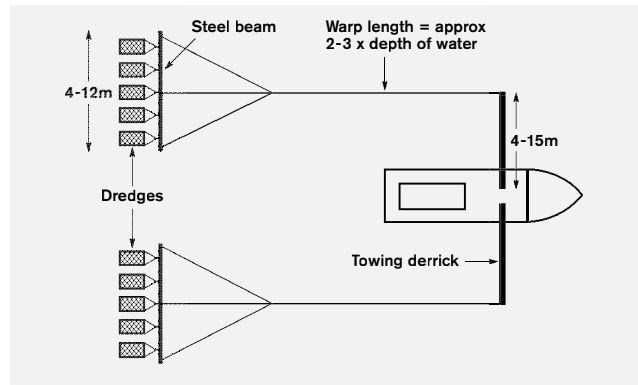

Fig 15. Typical dredge towing arrangement.

Deploying and retrieving the gear.

Main safety issues

- Manoeuvrability is restricted during all parts of the operation;
- Vessel should display a green light over a white light;
- Gear is generally astern of the vessel;
- Safe passing distance (astern) is at least 100m and may be more for a large vessel;
- Vessel is particularly vulnerable to wash or wake when deploying or retrieving the heavy gear.

The dredge is deployed either over the stern from an aft gantry, or over the sides on a derrick that can be swung outboard (see Fig 15), much in the same manner as the beam trawl. On retrieval, the single dredge is winched up into the aft gantry and emptied from its lower edge. Multiple dredges are winched inboard and turned upside down to empty the catch.

What is likely to be seen from the bridge of a larger vessel?

Day and night signals are the same as for the single boat trawling (i.e. two cones with pointed end together or green light over white light). Also look for:

- An outrigger or derrick on either side of the vessel which will be near horizontal when fishing.

What manoeuvres is the vessel likely to make?

The boat is likely to steam into the wind when hauling or shooting.

What are likely hazards / interactions?

Due to the heavy gear, the warps will not extend very far astern at the surface, so there is little chance of entangling. Passing too close may cause problems with wash / wake.

ENCIRCLING GEAR

General notes

This category includes purse seines and anchor seines / Scottish seines. Vessels using this type of gear should all show the same day shapes or lights as follows:

- By day, two cones pointing towards each other in a vertical line one above the other. Small vessels often fly an inverted basket in the rigging.
- By night, all-round red light over all-round white light, plus sidelights and sternlight when underway
- When there is outlying gear extending more than 150 metres horizontally from the vessel, an all-round white light or a cone apex upwards in the direction of the gear;
- A purse seiner should show a yellow light over a yellow light, flashing alternately; these lights may be exhibited only when the vessel is hampered by its fishing gear.

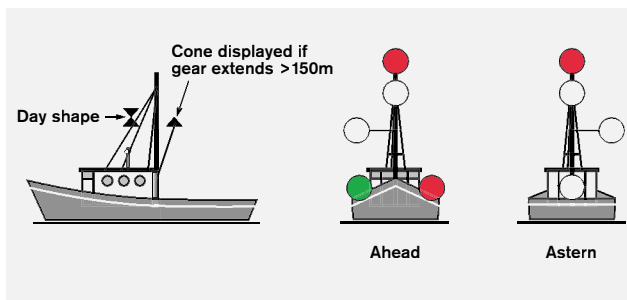

Fig 16. Day shapes and lights for fishing vessels other than trawlers

When fishing in close proximity to other fishing vessels the following signals should be shown:

- When shooting the net, two white lights above each other or Flag Z by day;
- When hauling the net, a white light over a red light, or Flag G by day;
- If net has become snagged on an undersea obstruction, a red light over a red light or Flag P by day.

The above all-round lights should be fixed lower than the main fishing lights and of lower intensity, but still visible at 1 mile.

Purse seines

Brief description of fishing method.

A purse seine is basically a wall of net that hangs vertically in the water with floats along the top and weights along the bottom. Also along the bottom edge is a series of rings through which a wire is threaded (purse wire). The net is set in a circle around a shoal of fish, then the purse wire is hauled in, causing the net to close at the bottom and thus trapping the fish inside. The net is then hauled on board until the fish are concentrated in a small volume of water from where they are removed.

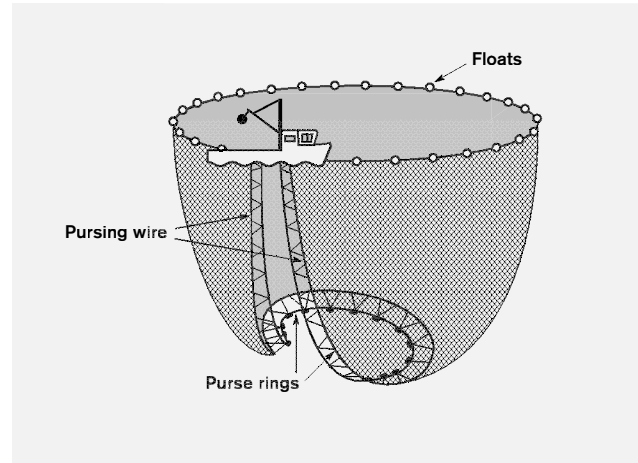

Fig 17. Purse seine, half closed.

The operation of a purse seine is often assisted by a small skiff or launch which is used to pull one end of the net off the larger vessel when setting the gear and may also be used to position the vessel or the net during hauling.

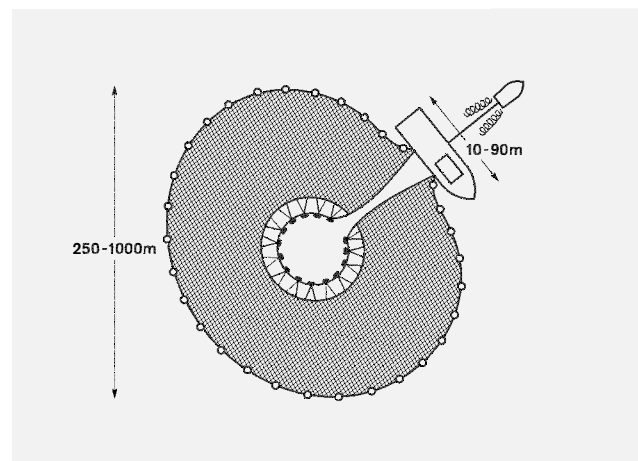

Fig 18. Plan view of purse seiner using a skiff to hold it clear from the net while hauling. Bottom of the net is almost closed.

Main safety issues

- Manoeuvrability is restricted during all parts of the operation;
- Vessel should display alternately flashing yellow lights;
- Safe passing distance is at least 500m from the vessel and may be more for a large vessel

Purse seining is used to catch shoals of free swimming (pelagic) fish such as mackerel, sardines, salmon, herring and tuna. Vessels using this method vary in size from small canoes of around 10m in length (common off the west coast of Africa in particular) to ultra modern vessels of 150m or more in length. The net on a large vessel may be as much as 2 km long and 200 m in depth.

Deploying and retrieving the gear.

Much of the time that a purse seiner spends at sea may be spent in searching for suitable concentrations of fish using sonar or visual lookout; during this time the vessel may steer a very erratic course.

When a suitable shoal of fish has been found the vessel will set its net around the shoal. In smaller boats, this involves heaving overboard one end of the net with a large float attached and steaming in a circle around the shoal until the float is reached. On larger vessels a skiff or launch may be launched, usually down a stern ramp, to which one end of the net is attached. This skiff steams in one direction while the main vessel steams away and in a circle until the two meet again, at which point the skiff hands its end of the net back to the master vessel.

As soon as the net is launched the vessel is very restricted in its ability to manoeuvre, and once the far end has been picked up, virtually no manoeuvring at all is possible.

The wire which passes through the rings at the bottom of the net (the purse wire) is drawn in as quickly as possible, preventing the shoal of fish from escaping downwards. At the same time, the body of the net is winched in, by hand on small boats or by the use of a hydraulic hauler (power block) on larger vessels. This process is known as "drying up" the net. The body of the net is stacked on board ready to be shot away again.

Once the net is dried up, the fish are removed by using a smaller net or, if the catch is small, simply by pulling the remaining bag of net on board. On larger vessels a fish pump will be used. The skiff is winched back up the stern ramp and the searching process starts again.

What is likely to be seen from the bridge of a larger vessel?

- Two yellow lights flashing alternately should be shown when the vessel has its nets deployed;
- Larger vessels are likely to have a power block at the end of a long derrick;
- Some tuna purse seiners operating in tropical waters will have one or more tall observation towers from where spotters will look for shoals of fish;
- On very large vessels, a helicopter may be used to assist in finding the shoals of fish;
- A skiff may be seen on a ramp at the stern of the vessel, particularly in tropical waters;
- When shooting the gear the vessel will be steaming in a tight circle (either to port or starboard, depending on which side the winches are situated);
- When hauling, a large amount of net will be seen passing through the power block;
- The floats supporting the net are often brightly coloured and easily seen;
- Small purse seiners commonly work at night, using bright lights to attract shoals of fish such as sardines;
- Smaller purse seine vessels may be indistinguishable from any other small vessel.



Fig 19. Large modern purse seiner showing two observation towers and two power blocks.



Figure 20: Older traditional purse seiner hauling nets over power blocks

What manoeuvres is the vessel likely to make?

When searching for fish the vessel may behave erratically and make sudden changes of course. When setting the gear the vessel will steam in a tight circle; the skiff may steam in the opposite direction. Small motorboats may be deployed to scare the fish away from the open section of the net. Once the net is deployed, the main vessel will not be able to make way through the water until hauling is complete.

What are likely hazards / interactions?

Entanglement with or crossing of the net would be very dangerous for the fishing vessel. With large purse seiners this should not occur, as the operation should be easy to identify, but with smaller, coastal vessels this may not be so easy.

Anchor seine / Scottish seine / Pair seine

Brief description of fishing method.

These methods are fundamentally similar and involve setting out long ropes on the seabed which, when hauled, are used to herd the fish towards the net. These seine ropes are weighted with a lead core and, when dragged along the seabed, create a large plume of silt or mud which the fish will swim away from and towards the mouth of the net. Consequently, these methods are most often used in daylight and in clear water. These methods are only suitable for use in

depths of up to around 150 m and on clear open ground, free of obstructions. Because the net is of lighter construction than a trawl and is not actively towed through the water, these methods are very fuel-efficient.

Anchor seining or Danish seining

Deploying and retrieving the gear.

An anchor is dropped and marked with a buoy; to this buoy the first leg of the seine rope is attached. The vessel then steams downtide and in a circle, paying out the ropes, setting the net across the tide and returning uptide to the buoy (Fig 21). Here, it ties up to the anchor, picks up the first seine rope and starts hauling both ropes (Fig 22, 1). As hauling continues, the net starts to close up and comes closer to the vessel (Fig 22, 2) until finally the net starts to close and the fish are herded into the net (Fig 22, 3). The net is then hauled on board and emptied, and is made ready for the next shot.

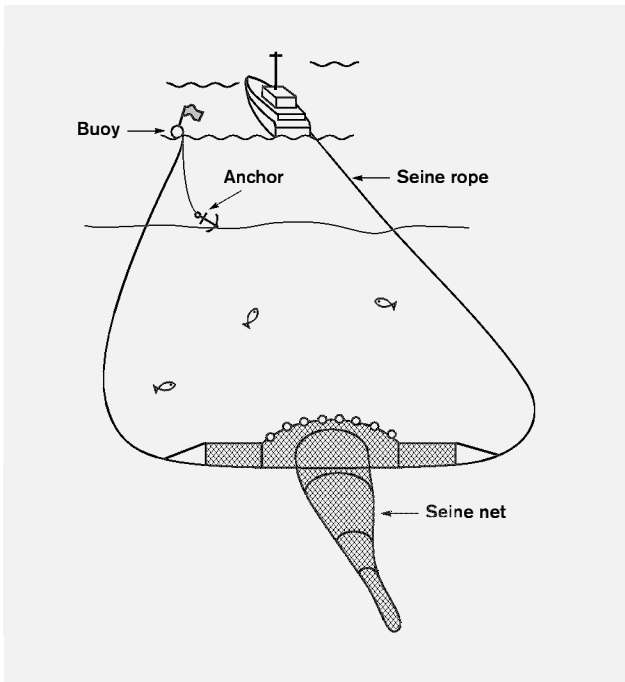

Fig 21. Anchor seine in final stage of deployment

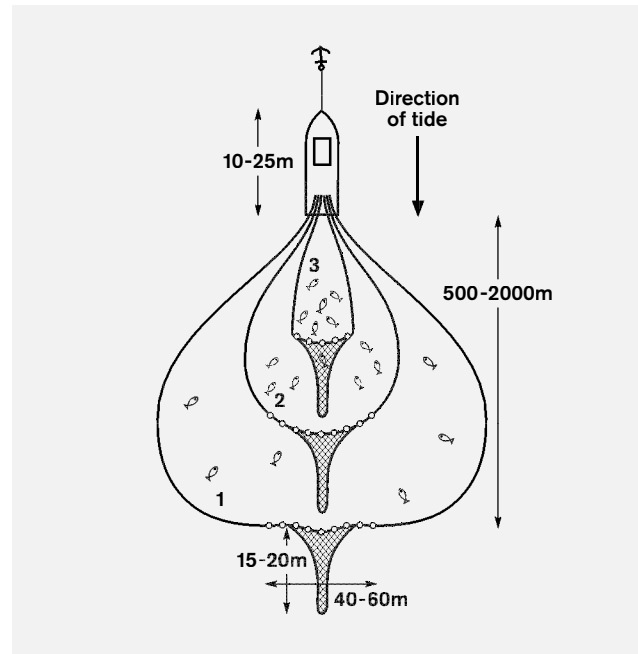

Fig 22. Plan view of anchor seine showing various stages of hauling.

Main safety issues

- Manoeuvrability is restricted during all parts of the operation;
- Frequent changes of direction while laying out net
- Vessel should display a red light over a white light;
- Gear is generally astern of the vessel;
- Safe passing distance (astern) is at least 200m and may be more for a large vessel;

What is likely to be seen from the bridge of a larger vessel?

- Many modern seine vessels will have a large, hydraulic rope reel situated aft;
- The deployment of the buoy and anchor might be visible;
- Fishing signals / lights should be as shown at the beginning of this section.

What manoeuvres is the vessel likely to make?

After deploying the anchor, the vessel will steam downtide, turn across the tide to lay the net and steam back uptide to pick up the anchor buoy and lie to the anchor. From this point the vessel will be unable to manoeuvre until the net is hauled and the anchor retrieved.

What are likely hazards / interactions?

When setting the gear, the seine ropes are a potential source for entanglement up to around 100 m behind the vessel; fouling at this point would likely cause capsizing of the fishing vessel.

Scottish seining and Pair seining

Scottish seining (otherwise known as fly dragging) is similar in principle to anchor seining, except that the first rope is attached to a buoy without an anchor and the vessel steams against the tide to lay out the first rope, turns to lay the net across the tide and returns downtide to pick up the buoy. With both ropes now onboard, the vessel steams with the tide, hauling slowly until the ropes come together and the net is brought on board. The advantage of this method is that more ground can be covered during each operation.

Pair seining is similar to Scottish seining, except that instead of returning to pick up the buoy, this is done by a second vessel. The two vessels then steam on a parallel course, slowly winching the net back and gradually coming closer together. When the net is close by, a messenger rope is sent across to the hauling vessel and the end of the seine rope transferred. The net is then hauled aboard and emptied, whilst the other vessel deploys its net ready for use. This method is very similar to pair trawling.

The observations and hazards for both of these methods are similar to those for anchor seining.

Passive mobile gear

General notes

This section deals with gear that is mobile (i.e. not fixed to the sea floor), but moves with the tide or the wind, and is not actively towed through the water by engine power. This includes surface drift nets, drifting long lines and some other hook and line methods. Although many other gears exist, these mentioned are the most common types of passive gear likely to be encountered.

Vessels using these types of gear should all show the same day shapes or lights as follows:

- By day, two cones pointing towards each other in a vertical line one above the other. Small vessels often fly an inverted basket in the rigging.
- By night, all-round red light over all-round white light, plus sidelights and sternlight when underway.
- When there is outlying gear extending more than 150 metres horizontally from the vessel, an all-round white light or a cone apex upwards in the direction of the gear;

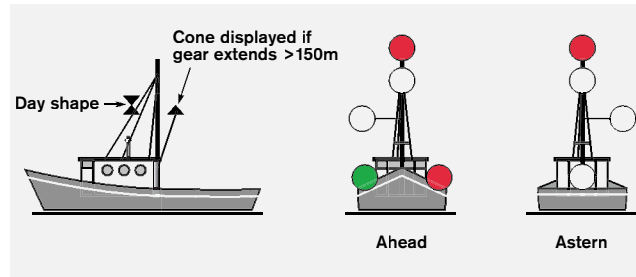

Fig 23. Day shapes and lights for fishing vessels other than trawlers

Surface drift nets

Brief description of fishing method.

This type of gear is a wall of netting suspended vertically in the water, with floats along the top rope and weights along the bottom. Fish swim into the net and are caught either by getting their gills lodged in the net, or they become entangled by their fins, spines etc. Different arrangements of gear may enable the net to fish below the surface, suspended from ropes and larger floats at the surface.

The net may vary in length between 100m and 25 km, though in some areas net length is restricted by legislation; for example drift nets of length greater than 2.5 km are banned in European waters. The longer nets are generally used on the high seas and away from major shipping lanes. Longer nets will generally have intermediate marker buoys and radar reflectors or radio beacons at intervals along their length.

These nets are used to catch many species fish that swim close to the surface, including tuna, salmon, herring, etc.

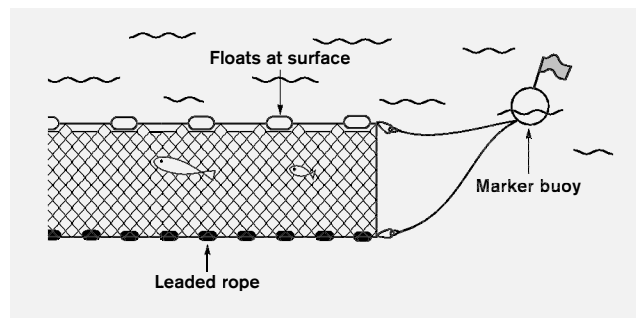

Fig 24. A surface drift net

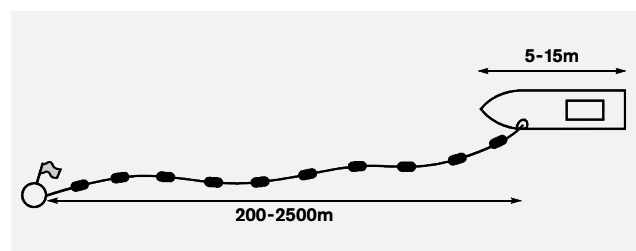

Fig 25. Plan view of surface drift net being hauled. Note that with larger vessels on the high seas, nets may be considerably longer than shown above.

Main safety issues

- Manoeuvrability is restricted during all parts of the operation;
- Vessel should display a red light over a white light;
- Gear may extend on the surface for very long distances from the vessel;
- Gear will usually be astern of the vessel while being set and ahead of the vessel when being hauled.



Fig 26. Typical West African drift net canoe, about 12 m in length. Note the lack of lights, fishing signals

Deploying and retrieving the gear.

Surface nets are almost always deployed over the stern of the vessel, often steaming at around 4 – 5 knots. If possible, the nets are set downwind. Once set, the nets are left to drift with current or wind, usually attached to the vessel although they may be left to drift independently. Sometimes, particularly with very long nets, the boat may steam back along the length of the net to the end that was first shot and start hauling from this end, thus allowing most of the net to be in the water and fishing for a similar length of time.

Hauling the net usually takes place over the bow or forward quarter, either by hand in small boats or through use of a hydraulic net hauler on larger vessels. The net is then cleared of fish and made ready for the next shot.

Some vessels, notably in inshore waters of the northwest Pacific, have a hydraulic net drum at the stern of the vessel; from which the net is both set and retrieved. Again, some have the drum mounted at the bow, set the net going astern and haul back onto the drum going ahead. Both of these have a limited net length due to the capacity of the drum.

What is likely to be seen from the bridge of a larger vessel?

- When setting the gear, activity and / or deck lights are likely to be seen around the stern of the vessel; floats and marker buoys may be seen on the surface; the gear will be streaming away astern of the vessel;

- When hauling, activity and / or deck lights are likely to be seen at the bow or forward quarter; the gear will be ahead of the vessel;
- Radar reflectors attached to the net may show on radar, usually every mile or so and often in a straight line;
- On larger vessels a hydraulic net hauler may be seen at the bow or forward quarter; on some vessels a net drum may be seen at the stern or at the bow;
- Lights and signals should be as shown at the beginning of this section.

What manoeuvres is the vessel likely to make?

No particular manoeuvres can be predicted. Some vessels may set their gear going astern, but these will be short nets.

What are likely hazards / interactions?

Wake or wash could cause problems to small vessels. Entanglement with the net close to the fishing vessel could cause capsize and sinking; at a distance of more than a few hundred metres the net is likely to break. Pass ahead of the vessel at a safe distance if it is seen setting the gear, and astern at a safe distance if seen hauling the nets.

Drifting long lines

Brief description of fishing method.

Here, a number of baited hooks are attached by short lines (droppers or snoods) to a main line which is kept near to the surface by means of floats. The gear drifts with the current, and is often attached to the vessel. Surface long lines may vary in length from 100m with maybe 30 hooks to 25 miles or more, with many thousands of hooks. The longest lines are mostly found on the high seas and usually well away from major shipping lanes. The line is often marked with radar reflectors mounted on buoys. Vessels using this method vary in length from small inshore canoes to large (>70m) industrial ships.

Surface longlines are used to catch a wide variety of species, notably tuna, swordfish, sharks and sailfish.

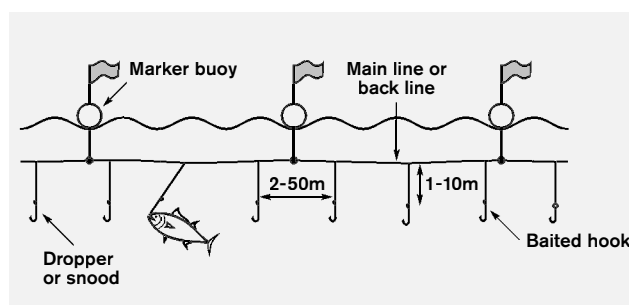

Fig 27. A surface long line.

Main safety issues

- Manoeuvrability is restricted during all parts of the operation;
- Vessel should display a red light over a white light;
- Gear may extend on the surface for very long distances from the vessel;
- Gear will usually be astern of the vessel while being set and ahead of the vessel when being hauled.

Deploying and retrieving the gear.

Longlines are almost invariably set over the stern and hauled over either port or starboard forward quarter. With a long set of gear, the vessel may finish shooting the line, steam along the length of it to the end that was first shot and start hauling from that end, ensuring that all hooks get a roughly equal fishing time.

In any but the smallest vessels, hauling is by a mechanical (usually hydraulic) hauler mounted forward.

What is likely to be seen from the bridge of a larger vessel?

- When setting the gear, activity and / or deck lights are likely to be seen around the stern of the vessel; floats and marker buoys may be seen on the surface astern of the vessel;
- When hauling, activity and / or deck lights are likely to be seen at the bow or forward quarter; the gear will be ahead of the vessel;
- Radar reflectors attached to the line may show on radar, usually every mile or so and often in a straight line;
- On larger vessels a hydraulic hauler may be seen at the forward quarter;
- Lights and signals should be as shown at the beginning of this section.

What manoeuvres is the vessel likely to make?

No particular manoeuvres can be predicted. When shooting or hauling the vessel will have restricted manoeuvrability. When hauling it will probably be head up to the wind.

What are likely hazards / interactions?

Wake or wash could cause problems to small vessels. Entanglement with the line close to the fishing vessel could possibly cause capsize and sinking; at a distance of more than a few hundred metres the line is more likely to break. Pass ahead of the vessel at a safe distance if it is seen setting the gear, and astern at a safe distance if seen hauling the lines.

Squid jigging

Brief description of fishing method.

This is one of the main methods of catching squid and is used worldwide, especially by vessels from Japan, Korea and China. It involves using special lures which attract and hook the squid. Up to 50 of these are used on each line, with a heavy weight on the end. On most squid vessels each of these lines is operated by a programmable, automated reel which lowers the line to the right depth and, when squid have taken the lures, reels them in. As the lures come over the rail the squid fall off the lures and onto a collecting tray. Up to 50 reels per side may be seen on larger squid vessels.

Most squid fishing takes place at night and the squid are attracted to the vessel by the use of very bright lights which can often be seen beyond the horizon.

Vessels using this method may vary from small inshore boats of less than 10m in length (where the gear is hauled by hand) to large industrial vessels up to 80m in length.

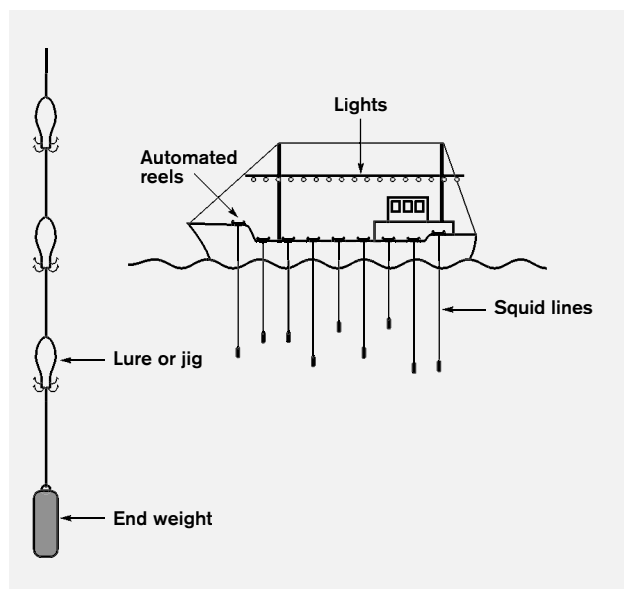

Fig 28. Diagram of squid line and of arrangement of lines on vessel.

Main safety issues

- Manoeuvrability is restricted during all parts of the operation;
- Vessel should display a red light over a white light; this will probably not be visible due to the intensity of lights used to attract the squid;
- Fishing lights can be very bright and reduce visibility of other hazards or navigation marks
- A sea anchor or drogue is often deployed from the bow of the vessel to slow the rate of drift.

Deploying and retrieving the gear.

The vessel may spend considerable time searching for squid using sonar and echo location. Once a suitable concentration has been found a sea anchor or drogue may be deployed from the bow to slow the rate of drift due to the wind, and remain over the shoal of squid. In addition, a spanker or mizzen sail may be set at the stern of the vessel to bring the head up into the wind. The collecting trays are lowered over the side to an angle of around 45 degrees and the lines are let down into the water.



Fig 29. Squid jigger deploying sea anchor, with jigging machines ready for fishing.

What is likely to be seen from the bridge of a larger vessel?

- At night, very bright lights may be seen from a considerable distance and can distract from other hazards / navigation aids;
- Smaller vessels may show fewer lights, but still bright enough to obscure fishing lights;
- Jigging machines and collecting trays may be seen projecting from side of vessel.
- A squid jigger can often be recognised by black streaks of squid ink on the sides of the vessel.



Fig 30. Squid fishing vessels at night

What manoeuvres is the vessel likely to make?

The vessel is not able to manoeuvre when the sea anchor or fishing gear is deployed.

What are likely hazards / interactions?

Wake or wash could cause problems to small vessels. Entanglement with lines is not an issue as they are deployed vertically downwards. It is best to pass astern of the vessel to avoid the sea anchor or drogue which may extend up to 200m ahead of the vessel.



Fig 31. A typical inshore squid jigger. Note the lights for attracting squid.

Static or fixed gear

General notes

These types of gear are generally fixed to the sea bed by anchors. They rely either on bait to attract the fish to the gear (hook and line, pots and traps), or on fish becoming entangled in the mesh of the nets (gill nets or tangle nets). Usually the gear is rigged to fish on or close to the seabed, but it can also fish close to the surface while still anchored.

The gear is deployed and left for a period of time (a few hours to, in some cases, a few days) when the vessel will return, haul the gear and harvest the catch. A major advantage of these methods is that they are fuel-efficient, and do not require heavy gear to be dragged over the seabed.

Vessels often fish many sets of gear which can be positioned between a few metres or a few miles apart. The vessels can thus appear to move erratically, being almost stationary while servicing the gear, then on completion of one set moving quickly and in any direction towards the next set.

A general feature of most of these methods is that the gear is deployed over the stern and hauled over the bow or forward quarter. Vessels using these static methods should show day signals and lights as for non-trawling fishing operations:

- By day, two cones pointing towards each other in a vertical line one above the other. Small vessels often fly an inverted basket in the rigging.

- By night, all-round red light over all-round white light, plus sidelights and sternlight when underway.
- When there is outlying gear extending more than 150 metres horizontally from the vessel, an all-round white light or a cone apex upwards in the direction of the gear;

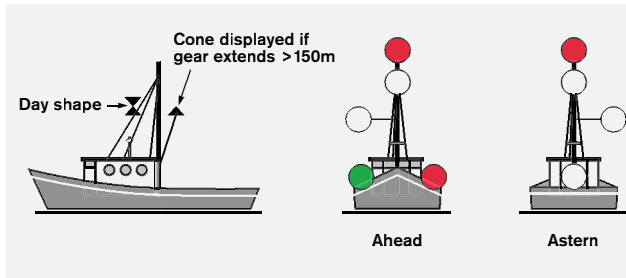

Fig 32. Day shapes and lights for static gear vessels

Fixed longlines

Brief description of fishing method.

Here, a number of baited hooks are attached by short lines (droppers or snoods) to a main line which is stretched between two anchors. Floats may be fixed along the main line to keep the bait away from the seabed. The ends of the line are marked with surface buoys. The length of the line may vary between 50m and 2-5 km; longer lines may have intermediate anchors along the length. Number of hooks may vary from 20 to 2,000. Lines may be set from a large reel at the stern of the vessel with the hooks being clipped on at intervals along the line. Vessels using this method range from small, inshore canoes to large, industrial vessels of 60m and over.

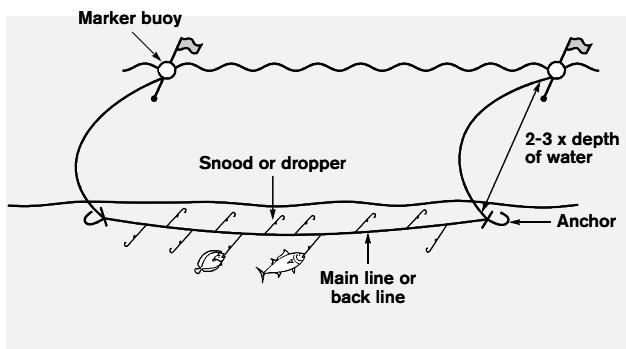

Fig 33. Bottom set fixed longline

Main safety issues

- Manoeuvrability is restricted during all parts of the operation;
- Vessel should display a red light over a white light;
- Gear will usually be astern of the vessel while being set and ahead of the vessel when being hauled.
- Vessels may move unpredictably and quickly between sets of gear
- Most of the length of the gear will be underwater; however, buoy ropes may extend a considerable distance aft when the gear is being set;

Deploying and retrieving the gear.

The gear is almost always set from the stern of the boat while steaming ahead. Typically the buoy and rope are set first, then the anchor goes over with the back line attached. The hooks may be baited before setting, or may pass through an automatic baiter which fixes the bait as the hooks go over the stern. Setting speed is usually between 2 and 5 knots. The line is generally (but not exclusively) set across the tide. One or more lines may be used. The gear is often targeted precisely on areas of rough ground or on wrecks as these are places that other fishing methods find difficult or impossible to work on.

The gear is left to fish until it is deemed time to haul – this can vary according to target species, bait type etc. When using a substantial length of line, the vessel may steam to the end of the line that was shot away first and start hauling from that end. Hauling usually takes place over the forward quarter, and, in anything but the smallest vessels, will be done using a hydraulic line hauler. The line is cleared of fish and made ready to be shot again. Sometimes two sets of gear are used, and the laborious task of baiting is done by a shore crew who prepare one set while the other is being fished.

What is likely to be seen from the bridge of a larger vessel?

- When setting the gear, activity and / or deck lights are likely to be seen around the stern of the vessel;
- When hauling, activity and / or deck lights are likely to be seen at the bow or forward quarter; the gear will be ahead of the vessel;
- On larger vessels a hydraulic line hauler may be seen at the bow or forward quarter;
- Lights and signals should be as shown at the beginning of this section.

What manoeuvres is the vessel likely to make?

- No particular manoeuvres can be predicted.

Vessels are likely to point upwind when hauling to avoid the line fouling the propeller. If the tide is stronger than the wind they will haul from the downtide end. They can move unpredictably and quickly from one set of gear to another.

What are likely hazards / interactions?

Wake or wash could cause problems to small vessels. The line should reach a safe depth within a short distance from the vessel, but entanglement could cause capsize and sinking of the fishing vessel. Pass ahead of the vessel at a safe distance if it is seen setting the gear, and astern at a safe distance if seen hauling the lines. Be prepared for sudden changes in speed or direction.

Baited pots or traps

Brief description of fishing method.

The baited pot or trap is a device which allows the target species (crabs, lobsters, shellfish, fish) to enter easily to attack the bait in the pot, but makes it difficult to leave the pot once inside. This is usually achieved by some sort of funnel device or one way valve. Traps vary between small devices, such as in the Korean octopus fishery where seashells of around 100mm are used to trap small octopus, to large wire mesh structures used in the Arabian Gulf, which may be as much as 2.5 – 3 m in diameter. Mostly they are in the range of 0.75m – 1.5m and light enough to be handled relatively easily, though some crab traps in the North Pacific may weigh as much as 120 kg even when empty.



Fig 34. Cuttlefish trap UK.

Traps are either used singly, with a buoy rope marking the pot, or in strings of up to 200, depending on the deck space of the fishing vessel. In the latter case, each pot is attached to a main back rope with a short dropper rope. Anchors or weights may be used at either end of the string to stop the gear moving in the current and a buoy used to mark each end.

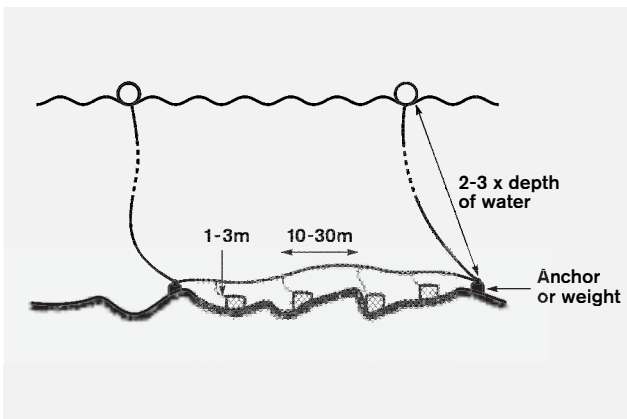

Fig 35. Layout of a string of pots. Number of pots per string varies with size of vessel.

Main safety issues

- Manoeuvrability is restricted during all parts of the operation;
- Vessel should display a red light over a white light;
- Gear will usually be astern of the vessel while being set and ahead of the vessel when being hauled.
- Vessels may move unpredictably and quickly between sets of gear
- Most of the length of the gear will be underwater; however, buoy ropes may extend a considerable distance aft when the gear is being set;



Fig 36. Modern potting vessel with full deck load

Deploying and retrieving the gear.

Pots are almost invariably set over the stern or from the aft quarter with the vessel steaming ahead. If being used in strings they are arranged on deck in the correct sequence for safe deployment. Setting speed may be as much as 5 – 6 knots. Gear is often set on rough ground where other fishing methods cannot be used, but, depending on the target species, may also be set over clean, open ground. The pots are left to fish, usually for at least 24 hours and often for up to 3 or 4 days.

Hauling generally takes place over the forward quarter or the bow. The pots are emptied of their catch, rebaited and stacked ready to be shot again.

What is likely to be seen from the bridge of a larger vessel?

- When setting the gear, activity and / or deck lights are likely to be seen around the stern of the vessel; floats and marker buoys may be seen on the surface; the gear will be streaming away astern of the vessel;
- When hauling, activity and / or deck lights are likely to be seen at the bow or forward quarter; the gear will be ahead of the vessel;
- Radar reflectors attached to the marker buoy may be seen;
- On larger vessels a hydraulic line hauler may be seen at the bow or forward quarter;
- Pots may be seen piled high on the deck;
- Lights and signals should be as shown at the beginning of this section.

What manoeuvres is the vessel likely to make?

No particular manoeuvres can be predicted. When hauling or shooting, the vessel will have restricted manoeuvrability. After hauling or shooting away the gear at quite slow speeds, the vessels can move quickly and in any direction to relocate the gear or attend to the next set of gear.

What are likely hazards / interactions?

Wake or wash could cause problems to small vessels. Entanglement with the back rope close to the fishing vessel could cause capsize and sinking; the gear should sink to a safe depth reasonably close to the vessel. Pass ahead of the vessel at a safe distance if it is seen setting the gear, and astern at a safe distance if seen hauling. Be prepared for sudden changes in speed or direction.



Fig 37. Large wire mesh fish traps commonly used in Gulf of Arabia and Red Sea.

Fixed gill nets / tangle nets

Brief description of fishing method.

These nets are usually a single sheet of netting with floats along the top edge (the headrope) and weights along the bottom edge (the footrope). Different arrangements of weights and floats allow these nets to be fished on the seabed (as in Fig 38 below), in midwater or at the surface. The net is anchored at either end and marked with buoys and possibly radar reflectors. The length of the net may be between 50 m and 1 – 3 miles and vessels using them vary between small inshore canoes and large (>50 m) industrial vessels. The nets work by ensnaring the target species, which is either trapped by the gills or is entangled by its spines. These methods are used worldwide to catch a wide variety of species.

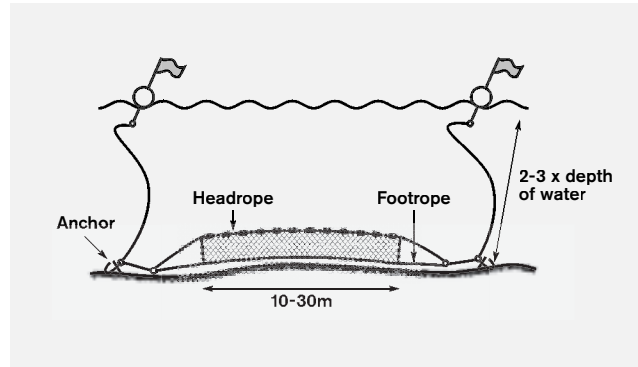

Fig 38. Anchored gill net rigged to fish on the seabed. Length of net used will depend on size of vessel.

Main safety issues

- Manoeuvrability is restricted during all parts of the operation;
- Vessel should display a red light over a white light;
- Gear will usually be astern of the vessel while being set and ahead of the vessel when being hauled.
- Vessels may move unpredictably and quickly between sets of gear
- Most of the length of the gear will be underwater; however, buoy ropes may extend a considerable distance aft when the gear is being set;

Deploying and retrieving the gear.

The nets are generally set over the stern or the aft quarter. The buoy is streamed away first, followed by the first anchor and the body of the net. The final anchor and buoy are then set. With very long nets there are sometimes intermediate anchors along the length of the net. On some vessels, notably in the northwest Pacific, nets are set from and hauled onto a large reel mounted either fore or aft.

The nets are left to fish for anything between a few hours and a few days. They are generally hauled over the bow or forward quarter often using a hydraulic net hauler. The fish are removed and the net is readied for its next use.



Fig 39. A typical gill net

What is likely to be seen from the bridge of a larger vessel?

- When setting the gear, activity and / or deck lights are likely to be seen around the stern of the vessel; floats and marker buoys may be seen on the surface;
- When hauling, activity and / or deck lights are likely to be seen at the bow or forward quarter; the gear will be ahead of the vessel;
- On larger vessels a hydraulic hauler may be seen at the forward quarter;
- Lights and signals should be as shown at the beginning of this section.

What manoeuvres is the vessel likely to make?

No particular manoeuvres can be predicted. The vessel will haul the gear with head up to the wind or the tide (whichever is stronger) to avoid tangling the net in the propeller. The vessels can move quickly and erratically from one set of gear to another.

What are likely hazards / interactions?

Wake or wash could cause problems to small vessels. Entanglement with the net close to the fishing vessel could possibly cause capsize and sinking; at a distance of more than a few hundred metres the net is likely to break. Pass ahead of the vessel at a safe distance if it is seen setting the gear, and astern at a safe distance if seen hauling the nets. Be prepared for sudden changes in speed or direction.

Lessons learnt from the incidents

- It is not always easy to determine what sort of fishing gear a boat is using, or sometimes even whether it is fishing or not;
- Fishermen are sometimes concentrating more on catching fish than on safe navigation; it may be best to assume that they are not aware of your presence;
- Fishing gear can sometimes extend very long distances from the vessel using it, sometimes many miles; if in doubt, assume the worst case;
- Fishing vessels can have many sets of fixed gear at sea at any one time and appear to move quickly and erratically between them
- Small fishing vessels may not show correct lights or signals, nor are they likely to have a VHF radio;
- Fishing vessels might use a number of bright lights to assist their crew when working on deck at night. These lights might interfere with the lookout on the bridge of the fishing boat.
- Do not assume that because you are in a channel, harbour approach or separation lane that the fishermen will know what regulations apply or that they will be in a hurry to get out of your way; sounding the ship's siren or horn will attract their attention;
- Any manoeuvres to avoid collision should start well in advance and should be large enough to ensure that the vessel passes clear from the fishing boat with adequate CPA;
- Always proceed with safe speed, making appropriate adjustments according to the visibility and intensity of traffic in the area;
- Inform Master if visibility reduces – lax practices in this regard should not be tolerated;
- When transiting areas where fishing traffic is to be expected, radars should be set in a way to facilitate the detection of small stationary or slow moving targets – long relative trails are a great tool in this regard. Clutter on the radar screen (especially in periods of rain) can prevent small targets to be discovered on time. Long relative trails will show that a target exists even though it might be hidden in the clutter. They also provide for an extremely useful visual indication of the danger of collision that a target on the radar screen might present.
- If possible, communicate, where necessary, with a loud hailer or VHF and find where the gear is deployed;
- Sound signals should be given as appropriate.
- In crowded areas it may be wise to station a lookout on the bow of your vessel, with means of communicating with the bridge;
- In a collision with a fishing boat, the fishing vessel will most likely suffer serious damages, will be in danger of sinking (with the associated loss of life) and will need immediate assistance. The main concern of the other ship, involved in the collision, should be to do their best to provide the required assistance. So if you think you might have hit a fishing vessel, stop immediately and check!

These notes are only intended as a guide and reference; they are not exhaustive and should not substitute the experience of the ship's Master.



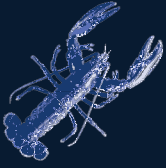

HOMARUS Limited

Fisheries and Aquaculture Specialists

Homarus Ltd provides technical and expert advice in fisheries and aquaculture matters. The company works internationally and is a leader in the field of fisheries and aquaculture damage assessment.

The company has long standing experience in technical support for P&I insurers. Company staff have worked all over the world on numerous P&I assignments in the last 26 years. Such assignments fall into the categories of

- Physical impacts: shipping collisions with fishing vessels, fish farms, fish and shellfishing grounds
- Pollution impacts: pollution of fishing grounds, fish and shellfish farms, sensitive habitats
- Temperature and contamination impacts to fisheries cargo, usually bulk frozen, sometimes containerised

Assessment work ranges from relatively minor interruptions to fishing income to major oil spill incidents with damage to multiple fishing or aquaculture interests. Homarus Ltd staff have established a reputation for being at the forefront of loss assessment methodology and advising on fisheries related compensation issues.

Homarus Ltd also assesses disruption to fisheries from other sources such as offshore wind farms, pipelines installation, sea defence work etc.

The company has its roots in shellfish production and in addition provides wider advice on the fisheries sector for a range of public and private sector organisations in the areas of:

- fishing industry studies
- fisheries socio-economic studies
- market analysis for fisheries products
- feasibility studies corporate analysis/due diligence

For more details please refer to website
www.homarusaquafish.co.uk

RISK FOCUS: CONSOLIDATED 2016

Since 2016, the Club's Loss prevention department have produced a consolidated Risk Focus publication combining all of that year's articles into one handy document. Articles on Enclosed Spaces, The Master Pilot Exchange, Moorings, Loss of Power, Slips, Trips and Falls, and Mental Health are all compiled in the 2016 edition, which can be downloaded from the UK Club website.



ENCLOSED SPACES

More needs to be done to stem the loss of life caused by this invisible killer. Accidents relating to entry into enclosed spaces on board ships continue to blight the shipping industry, with an unacceptably large number of incidents resulting in the death or injury of both ship and shore personnel reported over the first few months of 2016 alone.

THE MASTER PILOT EXCHANGE

Good communication and team work during pilot operations are key. When the mandatory berth to berth passage plan for a voyage is being prepared, it is often the information that is needed to complete the transit with the pilot onboard, to or from the berth, that is the most difficult to obtain in advance.

MOORINGS

With its team of risk assessors, the UK Club is in a unique position to gather data and target areas of risk onboard ship. In this article on mooring, we follow up on the Club's analysis of its mooring incidents. A twelve month exercise by the Club's in-house inspectors produced important supplementary findings.

LOSS OF POWER

Increasing numbers of main engine failure related incidents and accidents following blackouts have led to a data collection exercise by the UK Club's risk assessors and a detailed analysis of more than 700 claims, which has given cause for concern.

SLIPS, TRIPS AND FALLS

These represent nearly one in three of the large personal injury claims submitted to the UK Club. What is so special about slips, trips and falls? They are 'accidents' aren't they, part and parcel of life; maybe something which have to be expected aboard ships, which are mobile, sometimes even violently moving, places of work?

MENTAL HEALTH

Managing the emotional well-being of crew at sea.

GLOBAL NETWORK



Loss Prevention and Ship Inspections Department
Fax: +44 20 7283 6517
Team mailbox: lossprevention.ukclub@thomasmiller.com
shipsurveys.ukclub@thomasmiller.com
shipvisits.ukclub@thomasmiller.com

www.ukpandi.com