



## Chapter 54 – Lashing and Securing Deck Cargoes

For the purposes of this chapter, reference should be made to the *IMO Code of Safe Practice for Cargo Stowage and Securing* (CSS Code, Reference 22) and the requirements under SOLAS for a Cargo Securing Manual (CSM) (Reference 18).

### 54.1 Cargo Securing Manual (CSM)

Regulations VI/5 and VII/5 of the 1974 SOLAS Convention require cargo units and cargo transport units to be loaded, stowed and secured throughout the voyage in accordance with the CSM approved by the administration and drawn up to a standard at least equivalent to the guidelines developed by the IMO (Reference 18).

The guidelines have been expanded to take into account the provisions of the CSS Code (Reference 22), the amendments to that Code, the *Code of Safe Practice for Ships Carrying Timber Deck Cargoes* (TDC Code, Reference 23) and the codes and guidelines for RoRo vessels, grain cargoes, containers and container vessels, and ships carrying nuclear waste and similar radioactive products. Such individual publications are subject to amendments that need to be carried into the appropriate section of the CSM as they occur.

As from 1<sup>st</sup> January 1998, it is a mandatory regulation for all vessels, other than exempted vessels such as dedicated bulk solid, bulk liquid and liquefied gas-carrying vessels, to have on board an approved and up-to-date CSM. Some administrations may exempt certain cargo-carrying ships of less than 500 gross tons and certain very specialised ships, but such exemption should not be assumed in the absence of a formal exemption certificate.

It is a mandatory requirement for Masters and ships' officers to be conversant with the CSS Code and the CSM guidelines to understand their applications for the vessel in which they are serving and to be capable of deploying correctly the hardware that goes with them. The CSM and its associated hardware are subject to Port State Control (PSC) inspection. Violation of the CSM guidelines may give rise to vessel detention and/or prosecution of the Master and owners.

The CSS Code and the CSM guidelines and their amendments contain much sound and well-tryed advice and should not be treated lightly. There are, however, a number of anomalies and in some instances the applied text is difficult to reconcile with safe practice and sound seamanship.

### 54.2 Deck Cargo

The term 'deck cargo' refers to items and/or commodities carried on the weather deck and/or hatch covers of a ship and thereon exposed to sun, wind, rain, snow, ice and sea, so that either the packaging or the commodities themselves must be fully resistant to, and not denatured by, such exposure. Even in RoRo vessels, many areas above the actual hold space can reasonably be considered as 'on deck' even though they are not fully exposed to the wind and sea. The combined effects of wind, sea and swell can be disastrous. Where damage and loss occur to cargo shipped on deck at anyone's risk and expense, the shipowners, the Master and ship's officers, and the charterers, must be in a position to demonstrate that there was no negligence or lack of due diligence on their part.

Deck cargoes, because of their very location and the means by which they are secured, will be subjected to velocity and acceleration stresses greater, in most instances, than cargo stowed below deck. When two or more wave forms combine, a high wave preceded by a deep trough may occur. This may be referred to as an 'episodic wave', ie a random large wave, noticeably of greater height than its precursors or successors. This occurs when one or more wave trains fall into phase with another so that wave(s) of large amplitudes are produced, giving rise to sudden, steep and violent rolling and/or pitching motions of the ship. The risk is widespread and prevalent, as such waves have the potential to occur in any sea area. The stowage, lashing and securing of cargoes therefore require special attention as to method and detail if unnecessary risks are to be avoided.



**Figure 54.1:** Many areas above the actual hold space on RoRo vessels can reasonably be considered as 'on deck' even though they are not fully exposed to the onslaught of wind and sea.

### 54.3 Causes of Losses

Unfortunately, despite all the loss prevention guidance available, there is a continuing incidence of the collapse and/or loss overboard of deck cargo items. Losses include large vehicles, rail cars, cased machinery, steel pipes, structural steelwork, packaged timber, freight containers, hazardous chemicals, boats, launches, etc. When investigated fully, the causes of such losses generally fall into the following categories, which are neither exhaustive nor mutually exclusive in occurrence:

- Severe adverse weather conditions
- lack of appreciation of the various forces involved
- incorrect application of the relevant rules and guiding recommendations
- cost limitations for appropriate securing methods
- insufficient time and/or personnel to complete the necessary work before the vessel leaves port
- dunnage not utilised in an effective manner
- inadequate strength, balance and/or number of lashings
- wire attachment eyes and loops rigged incorrectly, including incorrect methods of using bulldog grips
- lack of strength continuity between the various securing components
- positioning lashing materials around unprotected sharp edges
- incorrect/unbalanced stowage and inadequate weight distribution
- securing arrangements, both supplied and approved, not fully utilised on the voyage under consideration.

This last point is particularly true of ISO freight containers and timber cargoes carried on the weather deck, and of large commercial vehicles carried in RoRo vessels.

All interests involved in the lashing and securing of deck cargoes should bear in mind that high expense in the purchase of lashing materials is no substitute for a simple design and a few basic calculations before lashing operations commence.



Figure 54.2: An example of best practice when securing cargo within a container.

Other than in RoRo and purpose-built container operations where standardisation of gear and rapid loading and turnaround times pose different problems, Masters should be encouraged, on completion of lashing operations, to make notes of the materials used, to produce a representative sketch of the lashing system, to insist upon being provided with the test/proof certificates of all lashing components involved and to take illustrative photographs of the entire operation. These will be of great assistance to the ship's interests in the event of related future litigation.

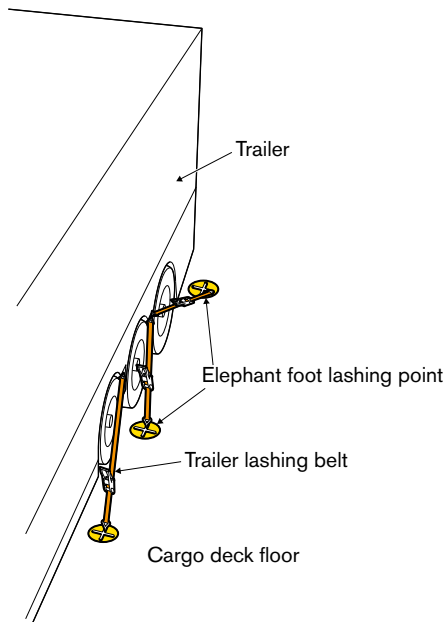

Figure 54.3: Lashing of cargo RoRo.

## 54.4 General Guidelines

The *Merchant Shipping (Load Lines) (Deck Cargo) Regulations, 1968* (United Kingdom Statutory Instrument No 1089 of 1968) (Reference 84) set out guidelines to be followed when securing deck cargoes. Although the 1968 Regulations have been formally revoked by the *Merchant Shipping (Load Line) Regulations 1998* and their provisions are no longer requirements, the list of elements they set out for consideration in relation to deck cargo (although not exhaustive) is useful to provide further understanding, as reproduced below:

*“2. Deck cargo shall be so distributed and stowed:*

- 1) as to avoid excessive loading having regard to the strength of the deck and integral supporting structure of the ship;*
- 2) as to ensure that the ship will retain adequate stability at all stages of the voyage having regard in particular to:*
  - a) the vertical distribution of the deck cargo;*
  - b) wind moments which may normally be expected on the voyage;*
  - c) losses of weight in the ship, including in particular those due to the consumption of fuel and stores; and*
  - d) possible increases of weight of the ship or deck cargo, including in particular those due to the absorption of water and to icing;*
- 3) as not to impair the weathertight or watertight integrity of any part of the ship or its fittings or appliances, and as to ensure the proper protection of ventilators and air pipes;*
- 4) that its height above the deck or any other part of the ship on which it stands will not interfere with the navigation or working of the ship;*
- 5) that it will not interfere with or obstruct access to the ship’s steering arrangements, including emergency steering arrangements;*
- 6) that it will not interfere with or obstruct safe and efficient access by the crew to or between their quarters and any machinery space or other part of the ship used in the working of the ship, and will not in particular obstruct any opening giving access to those positions or impede its being readily secured weathertight.”*

## 54.5 Dunnage

If all deck cargo items could be structurally welded to the weather deck using components of acceptable strength, this would remove the necessity to consider coefficients of friction between the base of the cargo and the deck or dunnage it is resting on. As the large range of deck cargoes have various securing arrangements, the possibility of a cargo sliding across the deck is high, which means friction should be considered in securing calculations.

The values given for the coefficient of friction between dry timber and dry steel vary from 0.3 (17°) to 0.7 (35°). Sliding between steel and steel can occur at angles of inclination as small as 6°.

Due to the lack of available data on the relative sliding properties of materials (in relation to deck cargoes at sea), an experiment was carried out using 9 inch × 3 inch × 8 feet sawn pine planks, some of which had earlier been allowed to float in water. Others had been stored in covered conditions to conform as closely as possible to normal atmospheric moisture conditions.

The experiments were carried out on hinge-opening hydraulic-powered steel MacGregor hatch covers in clean, painted condition, free of any unusual roughness and/or obstruction. The tests used dry timber on dry covers, wet timber on dry covers, dry timber on wet covers and, lastly, wet timber on wet covers. The lowest value, 0.51 (27°), occurred with wet timbers on wet covers; the highest value, 0.645 (33°), occurred with wet timber on dry covers.

On the basis of such results, the lowest value of 0.51 (27°) should be accepted as relating to the most common condition likely to be found on the weather deck of a seagoing ship, ie wet timber on wet decks. Hence, with inclination, and without any effects likely to be introduced by velocity and/or acceleration stresses due to rolling and pitching, timber dunnage alone will start to slide of its own accord at angles of inclination of 27°. Thereafter, sliding will continue at progressively smaller angles. It follows that, when the vessel is rolling and pitching and timber dunnage is unsecured, it will begin to slide at angles of inclination considerably less than 27°.

Normal practice of utilising timber dunnage and of keeping downward-leading lashings as short and as tight as possible should be encouraged. A near vertical lashing is of great benefit in resisting the cargo item's tendency to tip; a near horizontal lashing will greatly resist sliding forces.

It is important not to overload lashing terminals and/or shackles, and consideration should be given to the 'effective strength' of a lashing – its 'holding power'. The 'slip load' of an eye in a wire should be balanced with the strengths of a shackle, a bottle-screw and a chain. A lashing is no stronger than its weakest part.

## 54.6 Spread the Load

Point loading and uneven distribution of cargo weight can cause unnecessary damage to decks and hatch covers. Unless the weather deck has been specially strengthened, it is unlikely to have a maximum permissible weight-loading of more than 3 T/m<sup>2</sup>. Similarly, unless hatch covers have been specially strengthened, it is unlikely they will have a maximum permissible weight-loading of more than 1.8 T/m<sup>2</sup>. The ship's capacity plan and/or general arrangement plan should always be consulted. If the specific values are not available on board, allow no more than 2.5 T/m<sup>2</sup> for weather-deck areas; and no more than 0.75 T/m<sup>2</sup> for hatch covers in small vessels; and 1.30 T/m<sup>2</sup> in vessels over 100 m in length.

The adverse effects of point loading are not always fully appreciated. For example, a 6 T machine with a flat-bed area of 3 m<sup>2</sup> will exert a down load of 2 T/m<sup>2</sup> (see Figure 54.4).

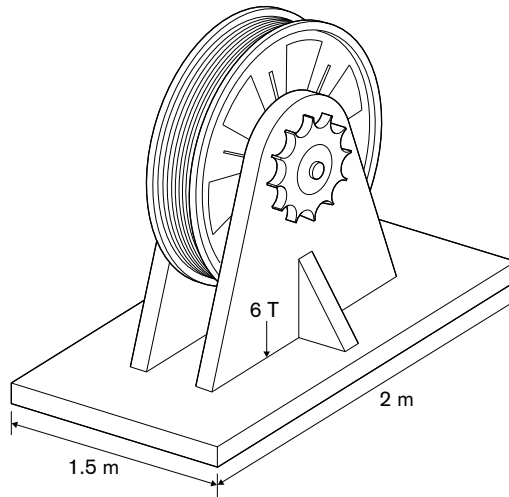

**Figure 54.4:** The 6 T weight is exerting a down loading of 2 T/m<sup>2</sup>.

When exceptionally heavy weights are to be carried, it may be necessary to support the weather deck from below, but care must be taken to spread the load on the tween deck in order not to overload the plating. Cargo units in the range of 20 to 40 T are common and stacking of unit weights is widespread.

For example, if a piece of machinery weighing 30 T, with a base area of 6 m<sup>2</sup>, is placed directly onto the weather deck, the point loading will be  $30/6 = 5 \text{ T/m}^2$ . If, however, the deck plating has a maximum permissible loading of 2.5 T/m<sup>2</sup>, the minimum area over which that 30 T load must be spread is  $30/2.5 = 12 \text{ m}^2$ .

Good dunnage must be used to spread the load, and it is always good practice to add 5% to the weight to be loaded before working out the dunnage area. For the 30 T weight, for instance, 31.5 T would be used for the calculation and the dunnage area required would increase from 12 to 12.6 m<sup>2</sup>.

Dunnage timber is often no more than 6 × 1 inch (150 × 25 mm) rough planking but, where weighty cargo items are involved, dunnage should be not less than 2 inch (50 mm) thickness × 6 inch (150 mm) width, and preferably 3 inch (75 mm) × 9 inch (225 mm). Thicker pieces of dunnage are frequently referred to as 'bearers'. A dunnage width greater than 150 mm is always acceptable, eg 9 inch (225 mm) to 12 inch (305 mm), but where the thickness is 3 inch (75 mm), care must be taken to choose straight-grained timbers of as great a width as possible and to ensure that they are laid with the grain horizontal and parallel with the deck. A singular piece of poorly constructed dunnage can set off a chain reaction in which the timber breaks, followed by a slackening of the lashing arrangements. This can cause increased cargo acceleration moments, culminating in the breaking of the lashings.

Because of the random nature of grain configurations in the thicker dunnage timbers, it is acceptable to achieve thicknesses by nailing planks together. A 2 inch thick



dunnage timber can be made up using 1 inch thick planks, and a 3 inch thick dunnage timber can be made up using 2 inch and 1 inch thick timber planks, all securely nailed together. To a large degree, this will correct the tendency for separation in timber with a badly-aligned grain.

If load-spreading dunnage is to remain fully effective, it will be as important to install good lower-level foot lashings as it will be to install downward-leading lashings. See Figure 51.5 in Chapter 51 for an example of a good foot lashing arrangement.

## 54.7 Rolling Periods

The roll period of a ship is the time taken to make one complete transverse oscillation, ie from the upright position to starboard inclination, from starboard inclination back to upright and through to port inclination, then back to upright. Hence, if the roll period is 15 seconds and if the roll to starboard is  $10^\circ$  and the roll to port is  $11^\circ$ , the total 'sweep' within the 15 second roll period will be  $10^\circ + 10^\circ + 11^\circ + 11^\circ = 42^\circ$ .

When a ship rolls, the axis about which the rolling takes place may not be accurately determined, but it is accepted as being near to the longitudinal axis passing through the ship's centre of gravity. The time period of the roll is generally independent of the roll angle, provided that the roll angle is not large. Therefore, a ship with a 15 second roll period will take 15 seconds to make one full transverse oscillation when the roll angle (to port and to starboard) is anything from, for example,  $2^\circ$  to  $30^\circ$ . From a cargo lashing viewpoint, a roll angle of  $2^\circ$  and a roll period of 15 seconds involves a sweep of no more than  $8^\circ$ , whereas a roll angle of  $20^\circ$  and a roll period of 15 seconds involves a sweep of  $80^\circ$  (10 times the arc) within the same time period. This will involve large transverse acceleration stresses, particularly when returning to the upright position.

Equally important is consideration of vertical acceleration as the ship pitches and ascends. Calculation of this force is difficult, but measured values give results varying from 0.5 g (gravitational acceleration) amidships to 2 g at the bow.

A 'stiff' ship is one with a large metacentric height (GM) that is difficult to incline and returns rapidly to the upright (and beyond). This imposes excessive acceleration stresses on cargo lashings. A 'tender' ship is one with a small GM that is easy to incline and returns slowly to the upright. Although acceleration stresses are small, the inclined angles may attain  $30^\circ$  and the simple gravitational effects of such angles and slow returns may impose equally excessive stresses on cargo lashings. Extremes of either condition should be avoided. It is worth working on the assumption that, if deck cargo is to remain safely in place during severe adverse weather conditions, the lashing arrangements should be sufficient to sustain  $30^\circ$  roll angles associated with 13 second roll periods, and  $5^\circ$  pitch angles associated with not less than 1 g vertical acceleration.

## 54.8 Rule of Thumb for Lashing Strength

A general rule for securing cargoes that may move during moderate weather on a voyage is that the sum of the minimum breaking loads (MBLs) of all the lashings should be not less than twice the static weight of the cargo to be secured. For example, a single item of 10 T weight requires the lashings to have a total breaking load of not less than 20 T, on the assumption that the lashings are all positioned in a balanced, efficient and non-abrasive manner. This rule may be excessive below decks.



Where winds of Force 6 and upwards together with associated wave heights are likely to be encountered during a voyage, the increased stresses arising are those considered here, allowing for 30° roll angles with not less than 13 second roll periods (also see Tables 54.3 and 54.4, taken from the CSS Code and the CSM guidelines).

In these circumstances, it is usually recommended that the SWL of all of the lashings should equal 3 times the weight of the cargo to be secured, ie a cargo of 10 T would require 30 T worth of lashings. This is again subject to the lashings being deployed in a balanced, efficient and non-abrasive manner.

This approach is derived from the *International Convention on Load Lines, 1966*, within which framework the then UK Department for Transport, in earlier instructions to surveyors, gave the following guidance:

*“When severe weather conditions (ie sea state conditions equal to or worse than those associated with Beaufort Scale 6) are likely to be experienced in service the following principles should be observed in the design of the deck cargo securing arrangements:*

*(iv) Lashings used to secure cargo or vehicles should have a breaking load of at least 3 times the design load, the design load being the total weight of the cargo or cargo plus vehicle subjected to acceleration of:*

*0.7 ‘g’ athwartships,  
1.0 ‘g’ vertically and  
0.3 ‘g’ longitudinally,  
relative to the principal axis of the ship.*

*When sea state conditions worse than those associated with Beaufort Scale 6 are unlikely to be experienced in service, a lesser standard of securing such items of cargo might be acceptable to approval by the Chief Ship Surveyor.*

*The equipment and fittings used to secure the deck cargoes should be regularly maintained and inspected.”*

Using the term ‘holding power’ to indicate breaking load/slip load/holding power, this means:

- The total holding power, in tonnes, of all lashings holding the cargo item vertically downward to the deck should be equivalent to three times the ordinary static weight of the cargo item in tonnes, ie a 10 T cargo item requires total lashings having a holding-down potential of 30 T
- the holding power, in tonnes, of all lashings preventing the cargo item moving to port and to starboard should be equivalent to seven-tenths of the holding-down potential of item 1 above, ie a 10 T item requires lashings with holding power preventing transverse movement of 21 T
- the holding power, in tonnes, of all lashings preventing the cargo moving forward or aft should be equivalent to three-tenths of the holding-down potential of item 1 above, ie a 10 T item requires lashings with holding power preventing longitudinal movement of 9 T.

The IMO 1994/1995 amendments to the CSS Code (Reference 22) (which were carried forward into the requirements for the preparation of the CSM) changed the emphasis as follows.

The CSM rule of thumb varies with the maximum securing load (MSL) of the different lashing components, as listed in Table 54.1. Vertical acceleration is replaced by a 1 g transverse acceleration, and vertical and longitudinal accelerations are not quantified except in the instance of containers of radioactive wastes.

The rule of thumb method given in Section 5 of Annex 13 of the current CSS Code (2021) indicates that the MSL values of the securing devices on each side of a cargo unit (port and starboard) should equal the weight of the unit, and Table 1 of Annex 13 of the Code now provides MSLs as follows:

Material	MSL
Shackles, rings, deckeyes, turnbuckles of mild steel	50% of breaking strength
Fibre rope	33% of breaking strength
Wire rope (single use)	80% of breaking strength
Web lashing	50% of breaking strength (was 70%)
Wire rope (re-usable)	30% of breaking strength
Steel band (single use)	70% of breaking strength
Chains	50% of breaking strength
<p>Annex 13 of the CSS Code also notes that:  <i>“Particular securing devices (e.g. fibre straps with tensioners or special equipment for securing containers) may be marked with a permissible working load, as prescribed by an appropriate authority. This may be taken as the MSL. When the components of a lashing device are connected in series (e.g., a wire to a shackle to a deckeye), the minimum MSL in the series shall apply to that device.”</i></p>	

**Table 54.1: Determination of MSL from breaking strength.**

Consider a cargo unit of 18 T mass which is to be secured using only shackles, web lashings, chains and turnbuckles – all MSLs of 50% breaking strength (BS). The unit will require 18 tonne-force MSL on each side, or 36 tonne-force total MSL (72 tonne-force BS for these items), representing a total lashing breaking strength to cargo mass ratio of  $72/18 = 4$ .

If the same cargo unit is secured with steel band only, the total MSL required will still be 36 tonne-force (72 tonne-force BS), but the MSL of steel band is nominated as 70% of its breaking strength. So this gives a total lashing breaking strength of  $(36 \times 100)/70 = 51.42$  tonne-force, representing a total lashing breaking strength to cargo mass ratio of  $51.42/18 = 2.86$ .

If using re-usable wire rope to secure the same cargo, the answer is  $(36 \times 100)/30 = 120$  tonne-force: ratio  $120/18 = 6.67$ . For wire rope, single use, the answer is

$(36 \times 100)/80 = 45$  tonne-force: ratio  $45/18 = 2.5$ , and for fibre rope the ratio is 6. These ratios (or multipliers) remain constant for equal cargo mass.

The CSS Code changes the commonly held understanding of the term 'rule of thumb' – a single multiplier easy to use and general in application – by inserting the MSL percentages to produce a range of rule of thumb multipliers.

Making use of Table 54.2, and in respect of any cargo mass, it is possible to use the multipliers without going through all the calculations previously described. More importantly, it can easily be seen the extent to which the MSL multipliers degrade or upgrade the generally accepted three-times rule.

In the instance of the 18 T cargo unit given above, the lashings' total breaking strength would be 54 tonne-force when the three-times rule is applied. Expressed simply  $18 \times 3 = 54$  tonne-force total BS, that is:

Cargo mass  $\times$  rule number = lashings' total breaking strength

Material	MSL	ROT multiplier
Shackles, rings, deckeyes, turnbuckles of mild steel	50% of breaking strength	4.00
Fibre rope	33% of breaking strength	6.06
Wire rope (single use)	80% of breaking strength	2.50
Web lashing	50% of breaking strength (was 70%)	4.00
Wire rope (re-usable)	30% of breaking strength	6.67
Steel band (single use)	70% of breaking strength	2.86
Chains	50% of breaking strength	4.00
<i>(Compare with overall general component)</i>	<i>(60.67% of breaking strength)</i>	<i>(3.00)</i>

**Table 54.2: Determination of MSL from breaking strength, including rule of thumb multipliers.**

## 54.9 Correction Factors

While the three-times rule may be considered adequate for the general conditions considered above, Section 7 of Annex 13 of the CSS Code (2021) provides Tables 3 and 4 where GMs are large and roll periods are less than 13 seconds. These tables, reproduced in this section, provide a measured way of applying that extra strength.

Length (m)	50	60	70	80	90	100	120	140	160	180	200
Speed (kn)											
9	1.20	1.09	1.00	0.92	0.85	0.79	0.70	0.63	0.57	0.53	0.49
12	1.34	1.22	1.12	1.03	0.96	0.90	0.79	0.72	0.65	0.60	0.56
15	1.49	1.36	1.24	1.15	1.07	1.00	0.89	0.80	0.73	0.68	0.63
18	1.64	1.49	1.37	1.27	1.18	1.10	0.98	0.89	0.82	0.76	0.71
21	1.78	1.62	1.49	1.38	1.29	1.21	1.08	0.98	0.90	0.83	0.78
24	1.93	1.76	1.62	1.50	1.40	1.31	1.17	1.07	0.98	0.91	0.85

**Table 54.3: Correction factors for length and speed.**

B/GM	7	8	9	10	11	12	13 or above
On deck, high	1.56	1.40	1.27	1.19	1.11	1.05	1.00
On deck, low	1.42	1.30	1.21	1.14	1.09	1.04	1.00
Tween deck	1.26	1.19	1.14	1.09	1.06	1.03	1.00
Lower hold	1.15	1.12	1.09	1.06	1.04	1.02	1.00

Note: The datum point in Table 54.3 is length of ship 100 m, speed of ship 15 knots and, in Table 54.4, B/GM <13.

**Table 54.4: Correction factors for B/GM <13.**

For all factors less than 1, it is safer to use 1 as the multiplier. For values greater than 1, Table 54.3 can be applied.

Section 6 of Annex 13 of the current CSS Code (2021) states:

*“6 Safety Factor*

*6.1 When using balance calculation methods for assessing the strength of securing devices, a safety factor is used to take account of the possibility of uneven distribution of forces among the devices or reduced capability due to the improper assembly of the devices or other reasons. This safety factor is used in the formula to derive the calculated strength (CS) from the MSL and shown in the relevant method used.*

$$CS = \frac{MSL}{\text{safety factor}}$$

*6.2 Notwithstanding the introduction of such a safety factor, care should be taken to use securing elements of similar material and length in order to provide a uniform elastic behaviour within the arrangement.”*

## 54.10 Breaking Strengths

The term 'breaking strength' is not defined in the CSS Code and the CSM guidelines, but within the context of those two documents, it could reasonably be taken to mean *the point at which the component, material or element can no longer support or sustain the load*, pending some possible amendments by the IMO.

The CSS Code (Reference 22) defines the values of MSLs of mild steel components for securing purposes as 50% of breaking strength (see Table 54.1). Chapter 2 of the CSM requires such components to have identification marking, strength test result or ultimate tensile strength result, and MSL<sup>1</sup> all to be supplied by the manufacturer/supplier with information as to individual uses. The CSS Code requires that manufacturers should supply strengths/MSL values in kilonewtons (kN). (To convert kN to tonne-force, multiply by 0.1019761 or, for a rough value, divide by 10.)

This mix of terms is likely to raise questions about the validity of the CSMs issued and/or approved to date. If the components are not identifiable by at least their MSLs, they are not compliant with the CSM guidelines. To overcome this problem, it has been suggested that all aspects could be safely met by attaching, with suitable wire, small coloured metal tags stamped with the MSL of the component, such as used for securing components for timber deck cargoes. Responses received from the industry support this proposal.

It is recommended that ships' officers and others trying to apply the requirements of the CSM/CSS Code should, if the chains, shackles, rings, etc available are not clearly identified as to their MSLs, use the stamped SWL of a lifting shackle as required by the CSM/CSS Code. This means using a component that may have a breaking strength two times greater than is needed but ensures compliance with the regulations. Alternatively, multiply the stamped SWL value by 4 to obtain the breaking strength and apply the percentages given in Table 54.1 to obtain the MSL; then remove that component from any possibility of use for lifting purposes by tagging it. This fulfils the spirit of the regulations without resorting to the use of massively oversized lashing components.

## 54.11 Wire Rope

For efficient lashing purposes, wire ropes should be round-stranded, flexible and easy to handle/manoeuvre. The most commonly used general purpose wire is 16 mm diameter (2 inch circumference) of 6 × 12 construction galvanised round strand with 7 fibre cores having a certificated MBL of 7.74 tonne-force. This wire will turn easily around thimbles and lashing points, can be spliced or bulldog gripped without difficulty and is easily handled.

Other wires of different construction and of varying sizes or strength may be needed for particular lashing purposes and the certificated MBL should always be verified before bringing such wires into use.

<sup>1</sup> Chapter 1.1 of the CSM gives the following definition:

*"Maximum securing load (MSL) is a term used to define the allowable load capacity for a device used to secure cargo to a ship. Safe working load (SWL) may be substituted for MSL for securing purposes, provided this is equal to or exceeds the strength defined by MSL."*

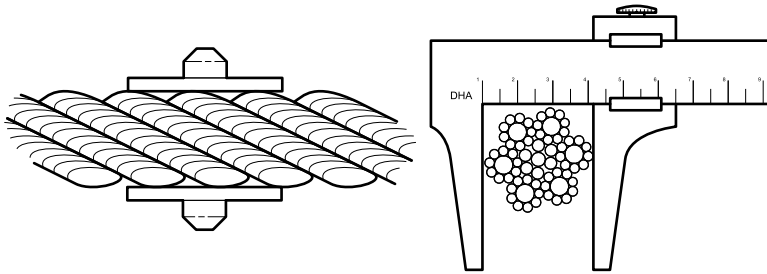

Correct method by which to measure the diameter of wire rope

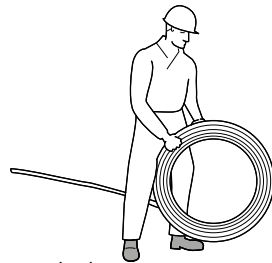
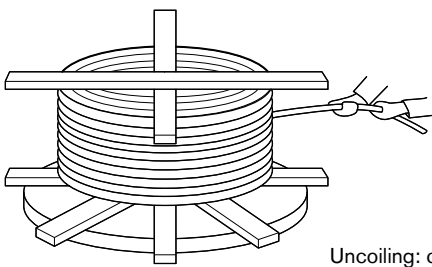

Uncoiling: correct method

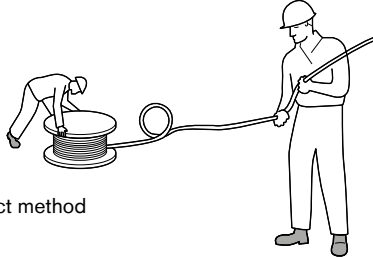
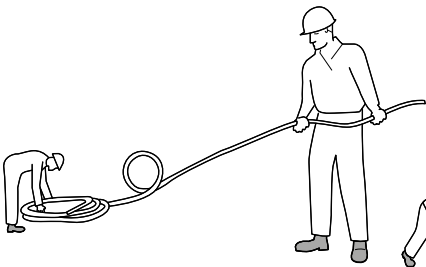

Unreeling: incorrect method

Figure 54.5: Wire rope.

Wires intended for use as lashings may be supplied pre-cut to a precise length and with eyes or attachment devices already formed in one or both ends. Such purpose-made items are usually sold with certificates stating the test load and minimum break load applicable. If test certificates are not supplied, they should be requested. More commonly, the wire is supplied in coils and must be cut to length on board ship with eyes and attachment devices formed and fitted as required. Where this is the case, eyes formed by bulldog grips must be made up in accordance with the manufacturer's instructions. If they are incorrectly fitted, they may slip under smaller forces than stated in the MBL.

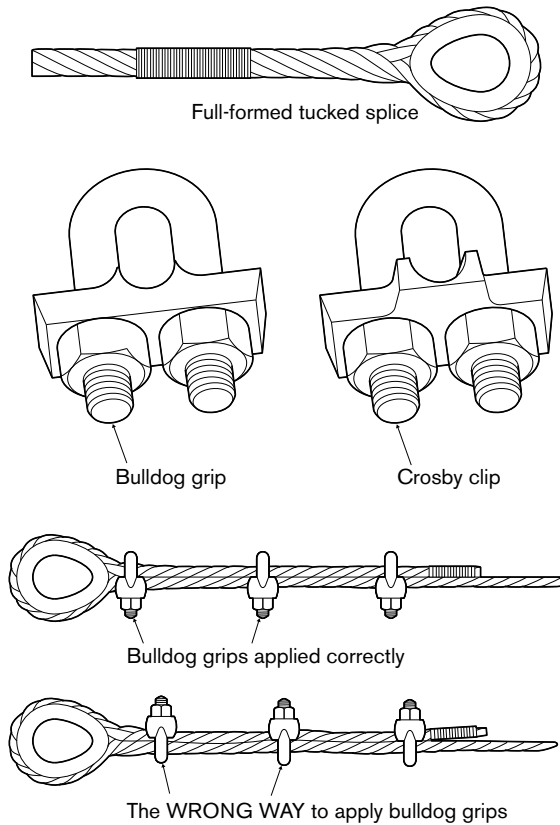

**Figure 54.6: Grips and clips.**

### 54.12 Bulldog Grips

The most common cause of lashing failure is incorrect application of bulldog grips. Where an eye is formed around a thimble in the correct manner, the lashing arrangement will hold secure with loads up to or even in excess of 90% of the nominal break-load (NBL) of the wire before slipping or fracturing, although it is usual and recommended to allow not more than 80%. Without a thimble, the eye, when made up correctly, can be expected to slip at loads of about 70% of the NBL. Where the correct procedures are not followed, slippage is likely to occur at much reduced loads.

Under strictly controlled conditions, more than 100 tests were applied on a licensed test bed on 16 and 18 mm wire rope lashing configurations (see Figure 54.7a, b and c). As a result of such tests, the recommendations in this section are made.

It should be stressed that these recommendations relate to cargo lashings only. Lifting gear and other statutory applications require a minimum of 4, 5 and 6 grips for 16 mm diameter wire and upwards, respectively. It is also most important to ensure that the bulldog grips are of the correct size in order to correspond with the diameter of the lashing wire.



Diameter of wire rope (mm)	Wire rope grips
Up to and including 19	3
Over 19, up to and including 32	4
Over 32, up to and including 38	5
Over 38, up to and including 44	6
Over 44, up to and including 56	7

**Table 54.5: Recommended minimum number of bulldog grips for each eye – lashing purposes only.**

An allowance of 150 mm should be made between the last bulldog grip and the end of the 'dead' wire. It is important to ensure that the lashing wires are not cut short immediately next to the bulldog grips. The end of the dead wire should be tightly taped.

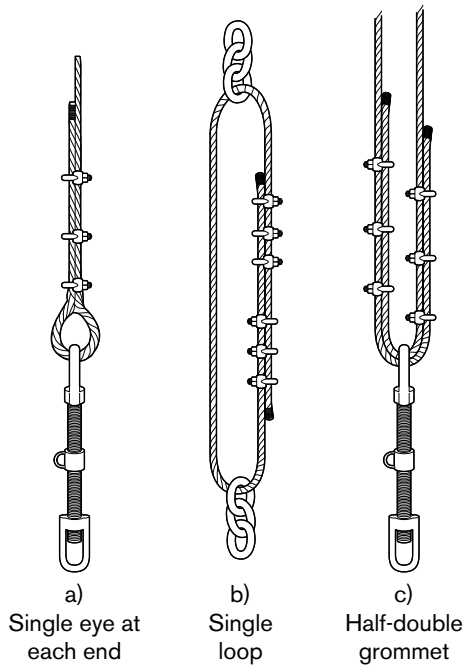

**Figure 54.7: Configurations tested.**

- Bulldog grips have a grooved surface in the bridge piece which is suitable for a standard wire of right-hand lay having six strands. The grips should not be used with ropes of left-hand lay or of different construction. Crosby grips have a smooth surface in the bridge piece. The first grip should be applied close to the thimble or at the neck of the eye if a thimble is not used. Other grips should be placed at intervals of approximately six rope diameters apart (ie 96 mm with a 16 mm diameter wire, 108 mm with an 18 mm diameter wire)

- the grips must all face in the same direction and must be fitted with the saddle or bridge applied to the working or hauling part of the rope. The U-bolt must be applied to the tail or dead-end of the rope. If the grips are not applied as indicated, the effectiveness of the eye can be seriously affected
- ideally, all the nuts on the grips should be tightened using a torque wrench so that they may be set in accordance with the manufacturer's instructions. In practice, it may be sufficient to use a ring spanner, although thereafter all the nuts should be checked periodically and adjusted as necessary

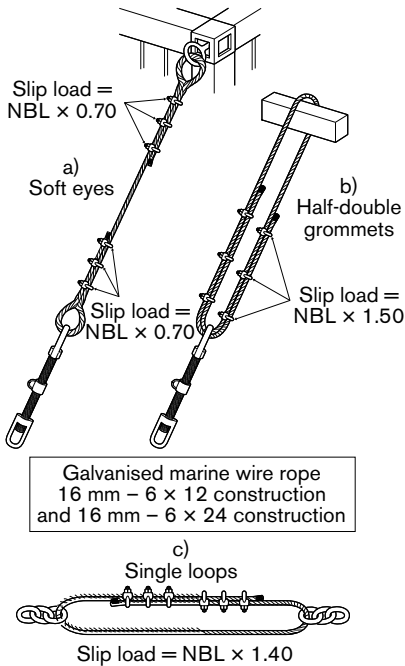

**Figure 54.8: Correct application of Bulldog grips.**

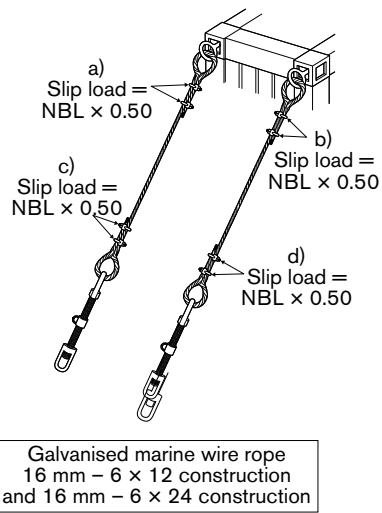

**Figure 54.9: Soft eyes – some other representative slip loads.**

- should a connection slip under load, it is likely that initially the rate of slip will be accelerated. The rate may then decrease but, until the load is removed, the slip will not be completely arrested
- the use of half-double grommets is common. Tests have shown that the slip load of this arrangement is only  $1.5 \times \text{NBL}$  (see Figure 54.8b). The holding power also decreases as the number of grips is reduced (see Figure 54.12)

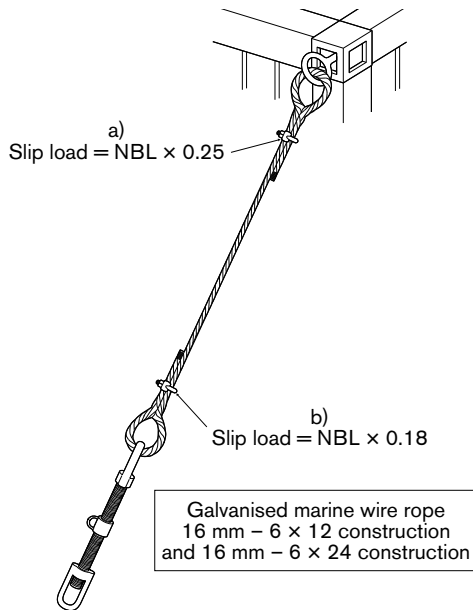

Figure 54.10: Soft eyes – UNSAFE application of Bulldog clips.

- the use of bulldog grips to join two ends of wire rope should be avoided. It is wrongly assumed that this will provide a holding power of  $2 \times NBL$ . In a single loop with six grips being used (see Figure 54.8), the slip load will be approximately  $1.4 \times NBL$ . The holding power decreases as the number of grips is reduced (see Figures 54.10 and 54.11)
- in a soft eye, with two grips and one or both used in the reverse manner (see Figure 54.9), the eye can be expected to slip at loads of about 50% of the NBL. These configurations are the least efficient

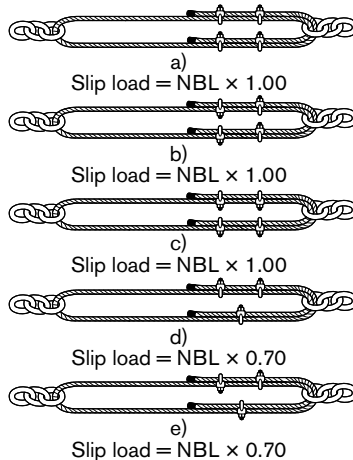
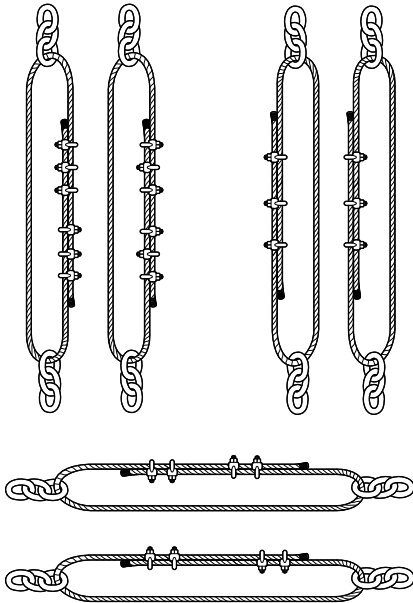
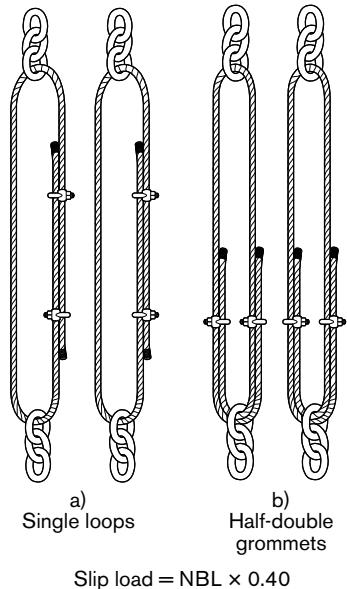

Figure 54.11: Half-double grommets – some other representative slip loads.

- with a soft eye, using only one grip, the slip load was found to be 0.25 NBL with the grip positioned correctly (see Figure 54.10a) and 0.18 NBL with the grip reversed (see Figure 54.10b)



**Figure 54.12: Single loops – some other representative slip loads.**



**Figure 54.13: NOT recommended.**

- a turnbuckle with a thread diameter of 24 mm or more can be adjusted to set up a pre-tension of about 2 T. If such a turnbuckle were attached to an eye made up in 16 mm wire, full tension in the wire would not be attained and the eye would slip at the grip under the pull of the turnbuckle alone.

Before deciding to use half-double grommets ( $NBL \times 1.5$ ) and single loops ( $NBL \times 1.4$ ) as opposed to single eyes ( $NBL \times 0.7$ ), it must be remembered that, at one terminal end in the instance of a half-double grommet, and at each terminal end in the instance of a single loop, there is no more material than at the terminal end of a soft eye.

If a properly made up single loop or half-double grommet breaks, this equals a loss of twice the holding power allowable for a soft eye. Therefore, it is most important to ensure that the terminal ends are connected by shackles or some other form of smooth component with no sharp edge.

Eyes and similar terminal ends in wire lashings should never be formed by the use of round turns and half hitches. Turns and hitches may slip and create sharp nips, leading to failure of the wire at loads well below those expected for eyes properly formed using bulldog grips.

When attaching wires to lashing terminals on the ship's structure or the cargo itself, every means should be taken to avoid hard edges, rough chafing points and sharp nips at the eye. Even where thimbles are not used, the attachment of the eyes of the wire to lashing terminals may best be accomplished by using shackles of the appropriate size and break load.

It must be ensured that the lashing points on the ship are sufficient in number and adequate in strength for the lashings they will hold.

### 54.13 Plastic-coated Wires

Plastic (PVC) coated galvanised standard marine wire of 18 mm diameter and 6 × 24 construction is commonly used for various purposes where there is a need to avoid the risk of cutting or chafing. Such wire should be used with caution because, if plastic-covered wire is used in conjunction with grips, slippage is likely to occur at lower loads than would be the case for unprotected wire of the same size and characteristics. The plastic coating should be stripped from the wire where the bulldog grips are to be applied and from the surface of any wires coming into contact with each other.

### 54.14 Fire and Explosion Hazards

Great care should be exercised if lashing terminals are to be welded during or after loading cargo. Before undertaking any hot work, it is important to obtain a hot work certificate from the local Port Authority. The authority should also be in possession of all relevant information relating to the ship and cargo. The welders themselves should be properly qualified and competent and, if welding is taking place either on deck or under deck, a proper fire watch should be mounted, both at and below the welding site. Adequate fireproof sheeting should be spread below welding points. On deck, fire hoses should be rigged with full pressure on the fire line.

A watchman should be posted for at least four hours after the completion of welding and a ship's officer should examine all spaces before they are finally battened down. These precautions should never be neglected and, if there is any doubt about safety, the welding must not go ahead.

### 54.15 Positive Action

It is important to be vigilant at all stages of the operation. If an officer or crew member sees a job being carried out incorrectly, the work should be stopped and reassessed.

### 54.16 Chain

Chain is widely used in the securing of freight containers, timber cargoes and vehicle trailers.

The use of chain alone for the securing of general deck cargoes is not widespread. Where chain lashings are used, they are usually supplied in precise lengths already fitted with terminal points and tightening devices.

The advantage of using chain is that, under the normal load for which the chain is designed, it will not stretch. Therefore, if all chain lashings are set tight before the

voyage and the cargo neither settles nor moves, nothing should cause the chain to lose its tautness.

In general, chain for non-specific uses is awkward to handle, tiresome to rig, difficult to cut to length and does not render easily. For general purposes, it is most effectively used in relatively short lengths in conjunction with, or as a part of, lashings otherwise composed of wire or webbing.

### 54.17 Webbing

The use of webbing slings and webbing lashings for cargo securing purposes has steadily increased over the past years, but operational results differ widely. There are instances where webbing is ideal for securing deck cargoes and there are other instances where it should be used with caution.

Special large bore pipes made of reinforced plastic, or provided with contact sensitive outer coatings, make webbing an ideal securing medium. The broad, flat surfaces and reduced cutting nature allow the webbing to be turned around and tightened against the pipes, producing a highly secure form of stowage.

Large, heavy, crated items or high standing heavy machinery, where relatively long spans may be involved, require wire or chain lashings. Sufficient unsupported tension is difficult to apply with webbing alone.

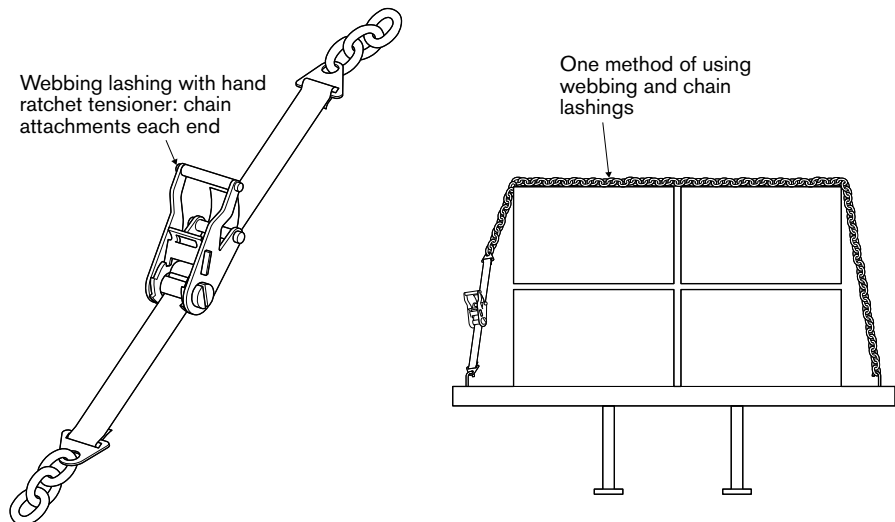

Figure 54.14: Webbing.

Webbing is usually manufactured from woven polyester fibre, therefore will stretch more than wire rope. It is supplied in reels and may be easily cut and fashioned to any required length.

Webbing should not be used without first confirming from the manufacturer's manual its nature, breaking load and application. Tension on a hand ratchet can be obtained easily up to 0.54 T and then with increasing difficulty up to a maximum of 0.60 T. A spanner

or bar must never be used to tighten a hand tension ratchet since recoil could cause serious injury.

Webbing should be kept away from acid and alkalis and care taken to ensure that it is never used to secure drums or packages of corrosive materials or chemicals because any leakage may damage and weaken the webbing. All webbing should be inspected frequently and, if re-used, care taken to ensure that all lengths are free from defects.

Protective sleeves should be used between webbing and abrasion points or areas. ISO freight containers should only be secured using webbing systems designed for such a purpose.

## 54.18 Fibre Rope

Ropes of up to 24 mm in diameter are handy to use but are more likely to be found on cargoes that are stowed below deck. The use of fibre ropes for weather-deck cargoes should be restricted to light loads of limited volume, in areas that are partly sheltered by the ship's structure. Where such ropes are used on deck, difficulty is likely to be encountered in maintaining the tautness of the lashings when they are subjected to load stresses and the effects of wetting and drying out in exposed situations. The use of turnbuckles should be avoided as they may easily overload the rope lashing. The tautening of rope lashings is best achieved by the use of bowsing ropes and frappings. At 24 mm diameter, a sisal rope has a breaking strain of 7.5 T and a polyester rope of 9 T.

Composite rope, frequently referred to as 'lashing rope', is made up of interwoven wire fibres and sisal or polypropylene fibres. The breaking strain of composite ropes should be considered as about 0.8 T for sisal-based and 1.8 T for polypropylene-based ropes.

Nylon fibre absorbs water and when under load this can reduce its effective strength by about 15%. Premature failure of nylon rope occurs under limited cyclic loading of up to 70% of its effective strength. Therefore, nylon rope is not recommended for deck cargo securing purposes.

The figures for breaking strain refer to new material and not to rope that has been in use for any length of time.

## 54.19 Shackles

Shackles are supplied in several shapes, sizes and strengths. The two shapes most commonly used in general cargo lashing are the D shackle and the bow shackle, each with an eyed screw pin. When using shackles, it is correct to define their strength in terms of the safe working load although, as indicated in Table 54.1, the CSS Code (Reference 22) and the CSM guidelines define their MSL as 50% of the breaking strength. Therefore, when preparing combined cargo lashings, it must always be ensured that the MSL of the shackles selected is not less than the effective strength of the eyes or other configurations formed in the wire rope and similar materials.



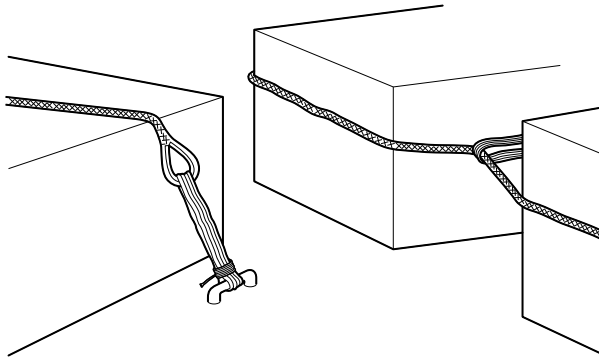

Figure 54.15: Tightening rope lashings.

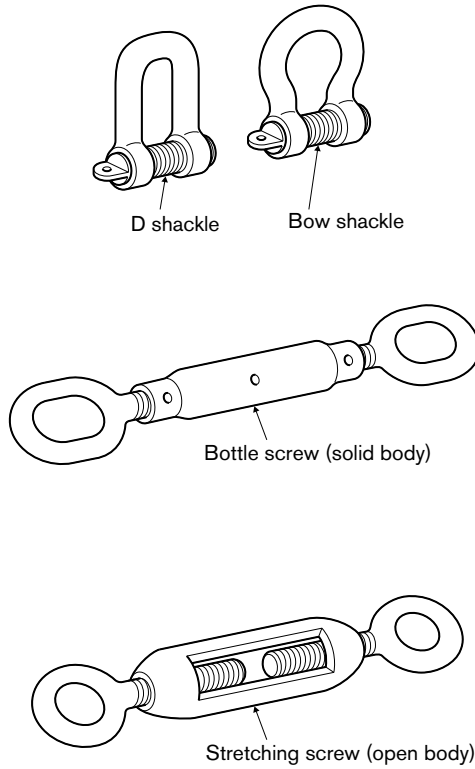

Figure 54.16: Shackles and screws.

## 54.20 Turnbuckles

The precautions for shackles also apply to the use of turnbuckles. The word 'turnbuckle' is used collectively to include solid-cased bottle screws and open-sided rigging screws or straining or stretching screws. These are most commonly used for general cargo lashing and are supplied in a range of sizes and strengths with a closed eye at each end. Open-sided rigging screws and straining screws tend to have noticeably lower strengths than solid bottle screws of the same size. The suppliers or manufacturers should be asked to provide the relevant test data so that the correct MSL or SWL can be ascertained before commencing lashing.

Solid bottle screws are typically sold by size of screw pin diameter. Those of 24 mm diameter have a proof-load of 4 T and those of 38 mm have a proof-load of 10 T. Special-purpose turnbuckles are available with much greater strengths than those given above. These may have particular fittings and modifications, such as those used in the container trade. Again, it is important to consult the manufacturer's manual before equipment is used.

Turnbuckles should always be used with the pulling forces acting in one straight line. They should never be allowed to become the fulcrum of angled forces.

Care should always be taken to ensure that the screws are at adequate extension when the cargo is finally secured. In this way, scope is provided for further tightening if this is required during the voyage as the cargo and lashing arrangements settle. Where high torque upon a main lashing is involved, the eyes of the turnbuckle should be seized or stopped against its own body in order to prevent the screws working back under load during the voyage.



**Price: £95**

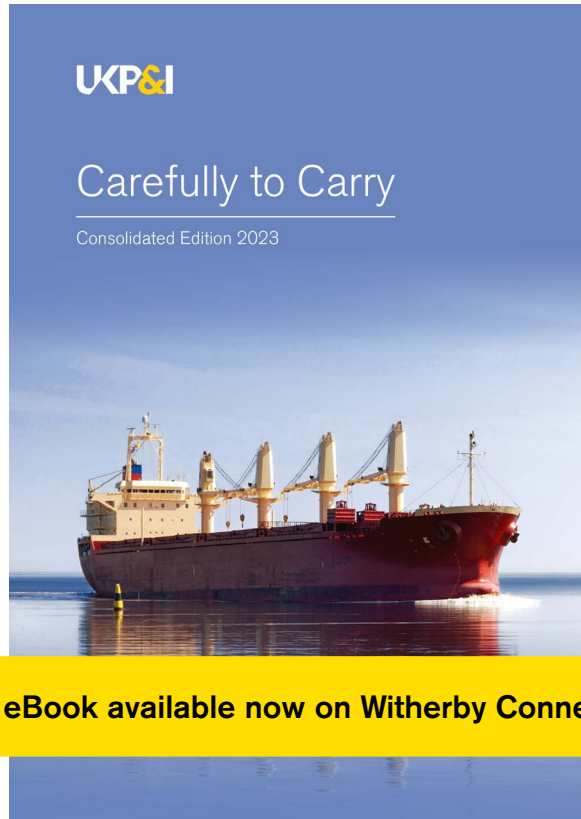

**Full eBook available now on Witherby Connect**

This comprehensive publication, compiled by the UK P&I Club, details best practice for the carriage, loading and storage requirements of a wide range of cargoes. It also contains essential information on draught surveys and preparing cargo plans.

Outlining and expanding on all major international cargo regulations and guidelines, it also includes detailed checklists, information on draught surveys and guides to preparing cargo plans. Cargoes covered include timber, gas, grain, steel and other metals, bulk goods and refrigerated goods.